

# Center for Leadership Inspire Architecture Group Kids' Home Architecture Camp

The situation we all find ourselves in under the current “Stay at Home” policies provide both a challenge and an opportunity. Parents are tasked to provide an educational experience for children with little practice and a need to entertain confined children. With this circumstance, the architecture community has an opportunity to provide leadership as a resource parents could access to provide both education as well as entertainment that both contribute to young people gaining a greater appreciation and understanding of architecture. To this end, I have put together an activity package and curriculum that AIA can make available to local communities and individuals to share in providing the resource to support the effort to educate and entertain through architecture.

In the following pages, I have embedded programs that address several areas of activity that can be applicable to a variety of age and school levels. We just need to find a way to deliver the “tool kit” for the “Kids' Home Architecture Camp” into the hands of parents across the country. In the end, we will contribute to not only providing education and entertainment for confined students, but also help cultivate a better understanding and appreciation for the built environment and how it got that way.

The Kit includes exercises and activities in:

1. Section 1: Drawing and coloring
2. Section 2: Learning about architects
3. Section 3: Design experience
4. Section 4: Model building
5. Section 5: Principles for structures
6. Section 6: Learning about important architecture
7. Section 7: Sustainability

The only materials needed include: paper, crayons, tape, scissors household items and some imagination. Each segment will have a lesson and activity oriented for young children and older students.

Sincerely,

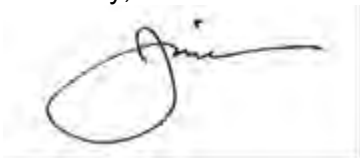

Hon. Judson A. Kline, FAIA, NCARB, LEED AP  
President CIVITAD Services, LLC  
3959 Oranewood Drive Orange Village, OH 44122  
216-469-5370 [jkline@civitadservices.com](mailto:jkline@civitadservices.com)  
[www.civitadservices.com](http://www.civitadservices.com)

# Center for Leadership Inspire Architecture Group Kids' Home Architecture Camp

## Section 1: Drawing and Coloring

### Lesson:

Of all the skills architects develop to express themselves, the most elemental is that of drawing, sketching and coloring. The ability to both visualize and then represent their ideas enables architects to share and communicate their concepts with others and to refine their designs for real application.

We will explore these areas of activity beginning with understanding a set of common ways architects depict their projects. Architects use three terms to understand and communicate their designs so they can be comprehended. These are; PLAN, ELEVATION and SECTION.

- PLAN:** A horizontal view of the structure as if you took a slice through the building at a point about four feet above the ground (see example images below\*).
- ELEVATION:** A vertical straight on view depicting the plane of each side of the building (see example images below\*).
- SECTION:** A drawing showing a vertical slice through the building that shows structure and relationship of vertical elements including openings in floors (see example images below\*).

### Activity:

- Older students- Considering your house draw a floor plan, front elevation and a section. If you like doing these drawings develop upper floors and the other elevations of the house.
- Young students- Color a picture included among the attached images.

\*All examples are provided by the architect and taken from the Veteran's Tiny House Village Project.

# Center for Leadership Inspire Architecture Group Kids' Home Architecture Camp

Plans:

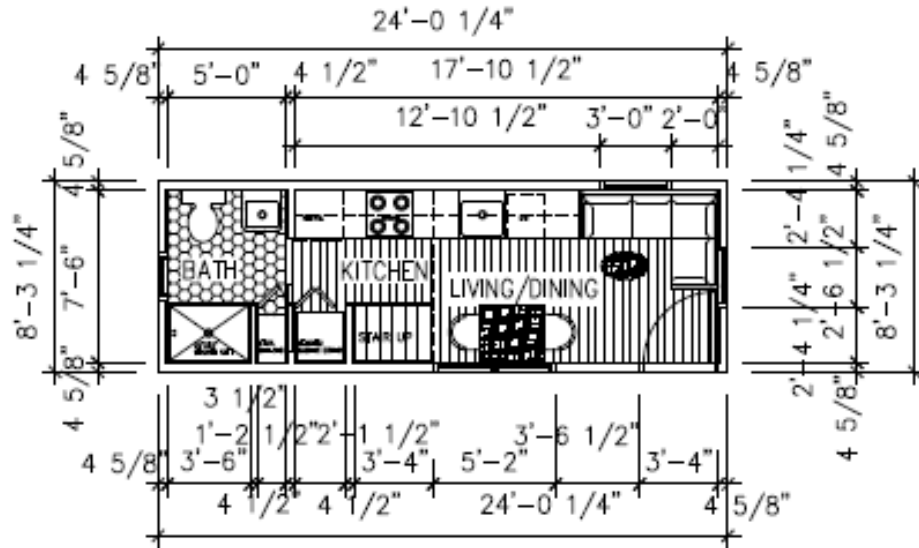

**MAIN FLOOR PLAN**

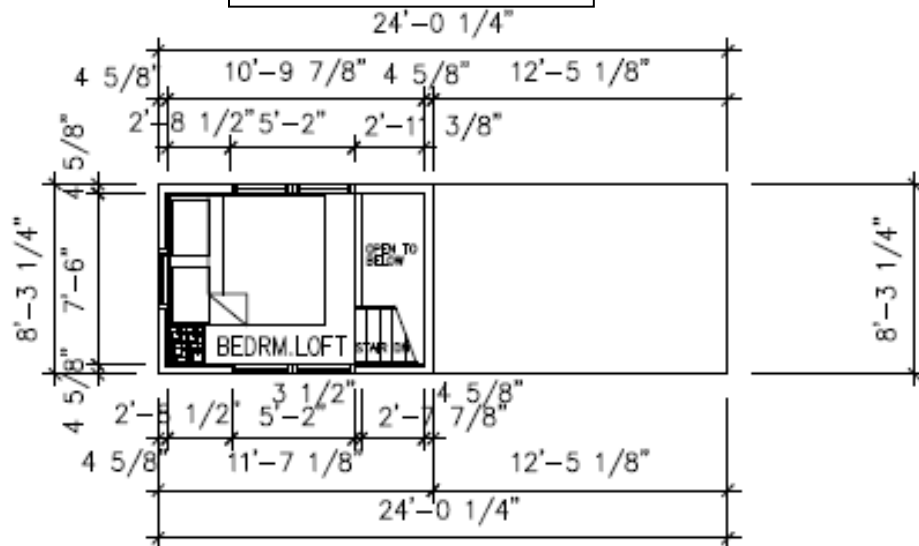

**LOFT FLOOR PLAN**

# Center for Leadership Inspire Architecture Group Kids' Home Architecture Camp

**ELEVATIONS:**

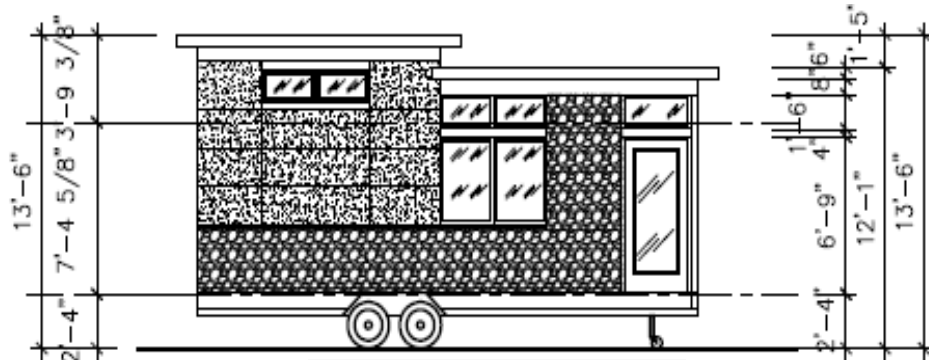

**FRONT ELEVATION**

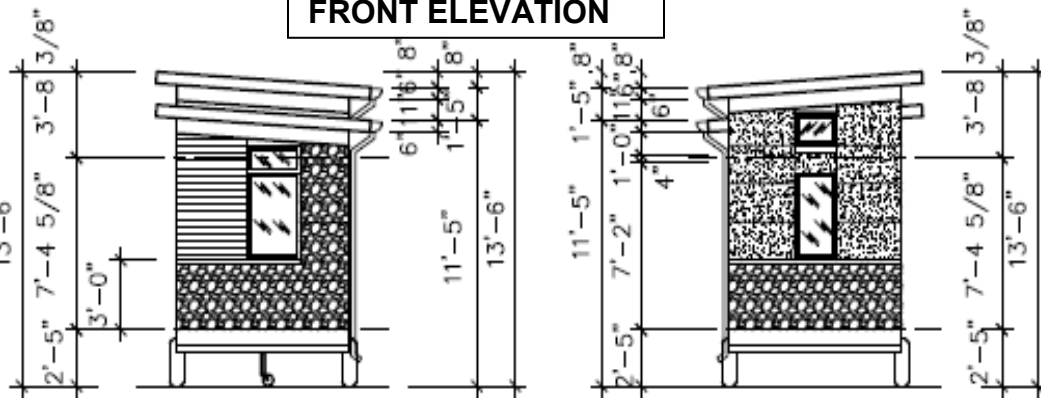

**RIGHT SIDE ELEVATION      LEFT SIDE ELEVATION**

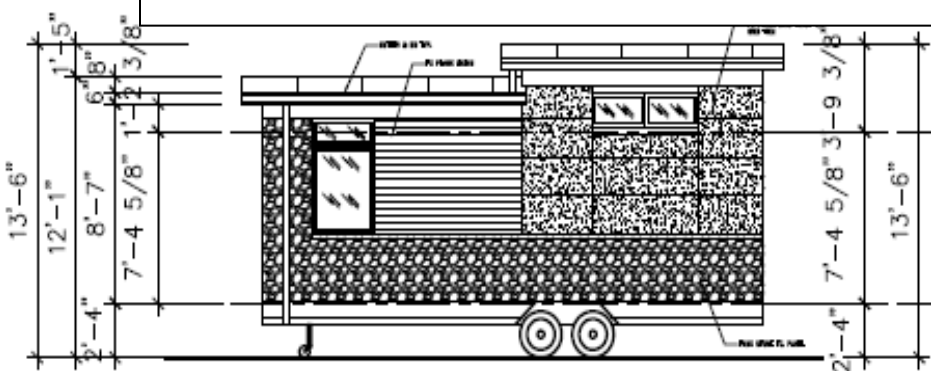

**REAR ELEVATION**

# Center for Leadership Inspire Architecture Group Kids' Home Architecture Camp

SECTIONS:

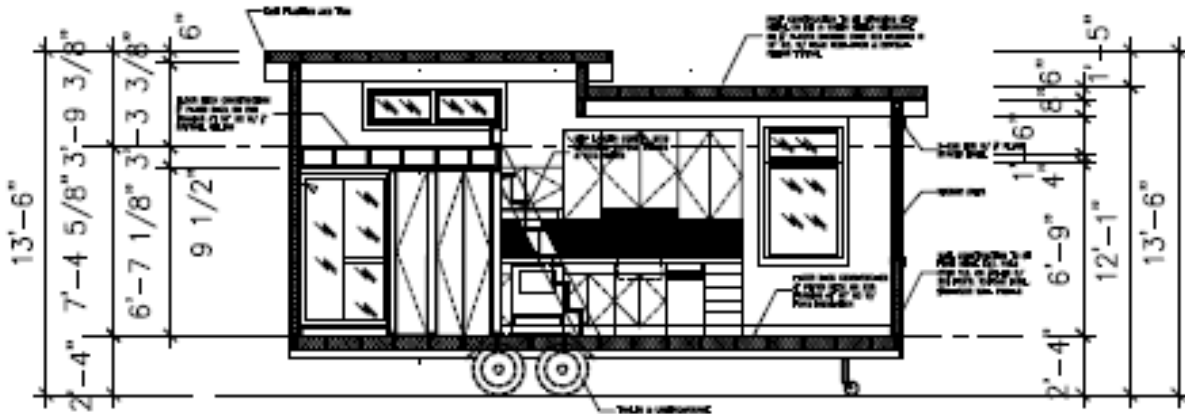

LONG SECTION LOOKING TO BACK

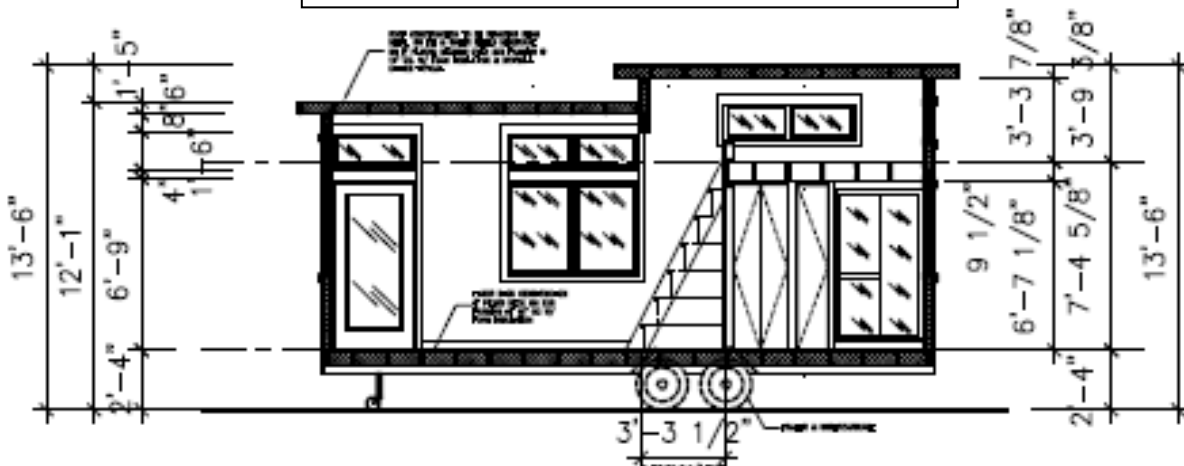

LONG SECTION LOOKING TO FRONT

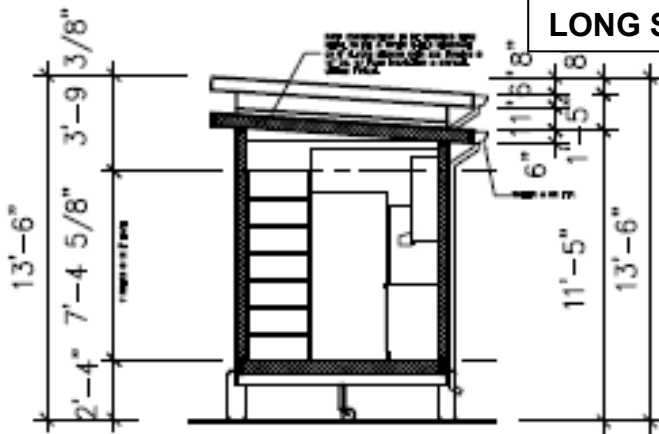

CROSS SECTION LOOKING LEFT

# Center for Leadership Inspire Architecture Group Kids' Home Architecture Camp

**COLORING**  
permission from  
Coloring Book)

**BOOK** (Taken with  
the AIA Cleveland

**Louis Penfield Residence**  
Cleveland, Ohio  
excerpt from the Cleveland Architecture Coloring Book V.3

**Frank Lloyd Wright**  
Illustrated by Jeremy Smith  
**1955**

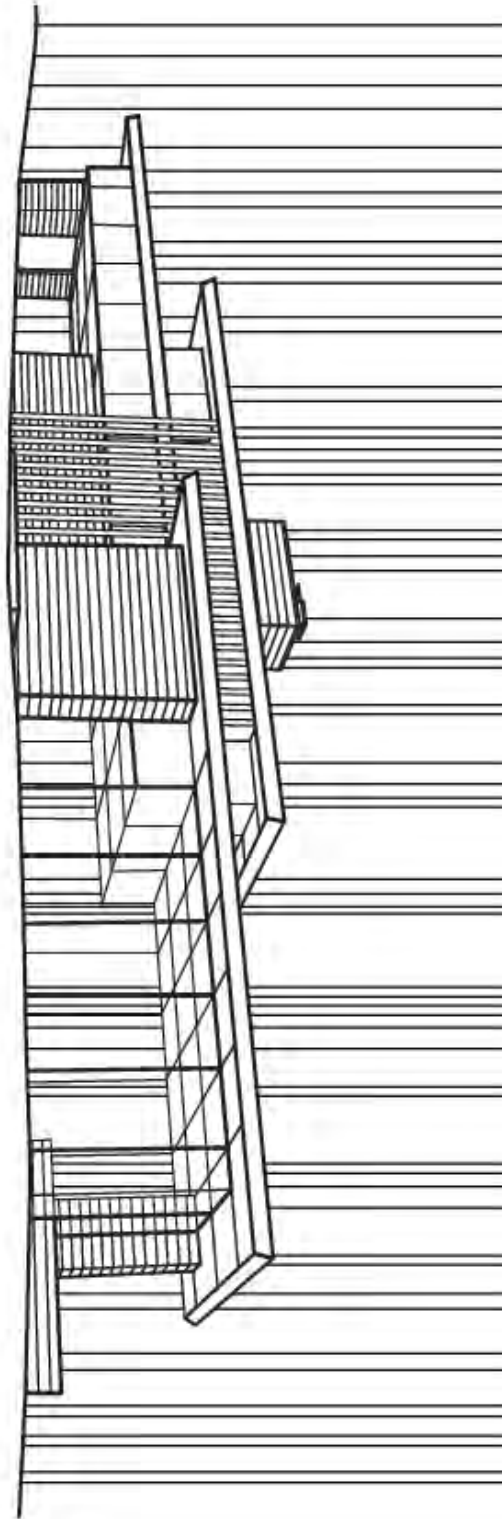



# Center for Leadership Inspire Architecture Group Kids' Home Architecture Camp

**ASM World Headquarters**  
Nowelky, Ohio  
excerpt from the Cleveland Architecture Coloring Book V.3

**John Terence Kelly and R. Buckminster Fuller**  
Illustrated by Jeremy Smith

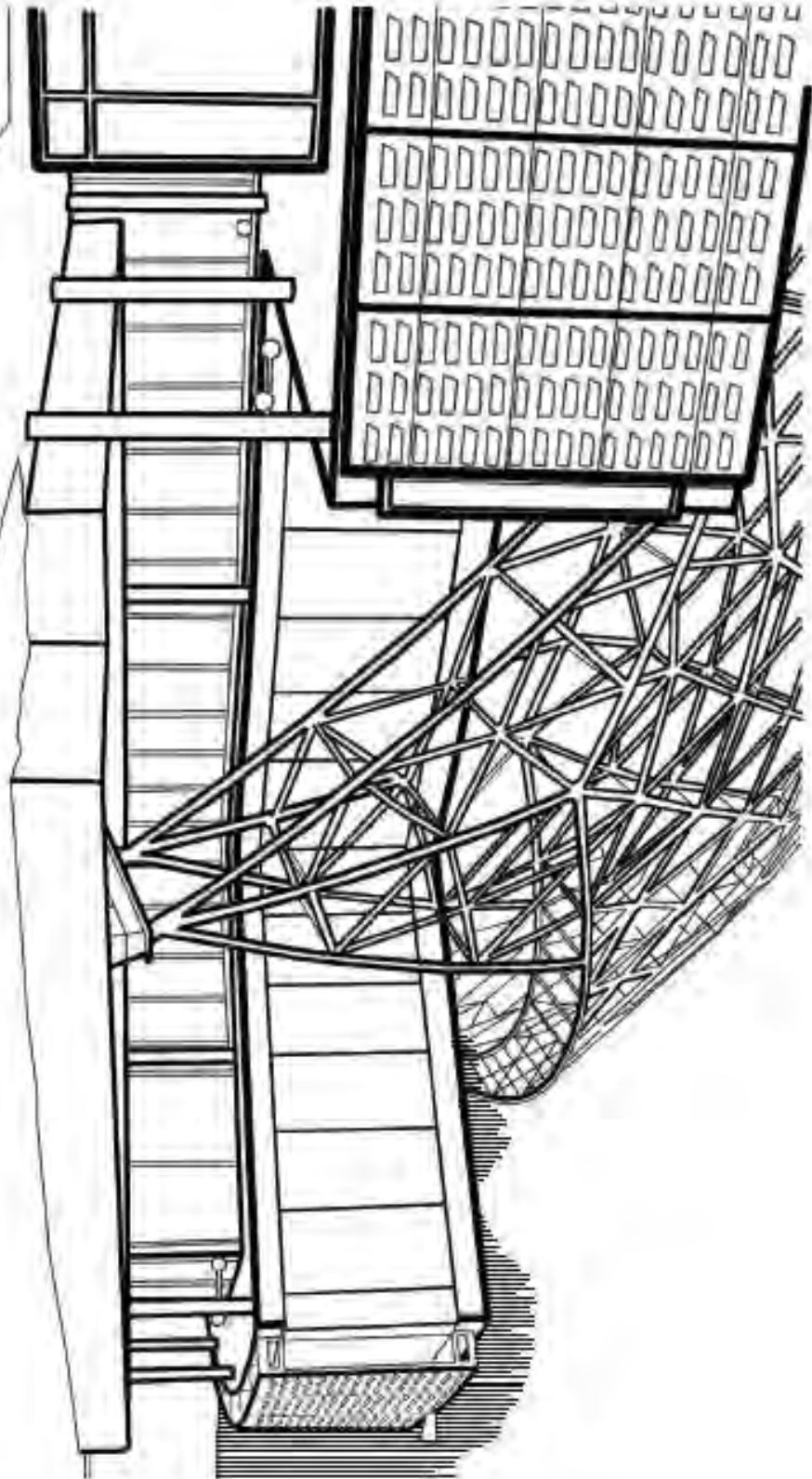

# Center for Leadership Inspire Architecture Group Kids' Home Architecture Camp

**Pro Football Hall of Fame Competition Entry**  
Canton, Ohio  
excerpt from the Cleveland Architecture Coloring Book V/3

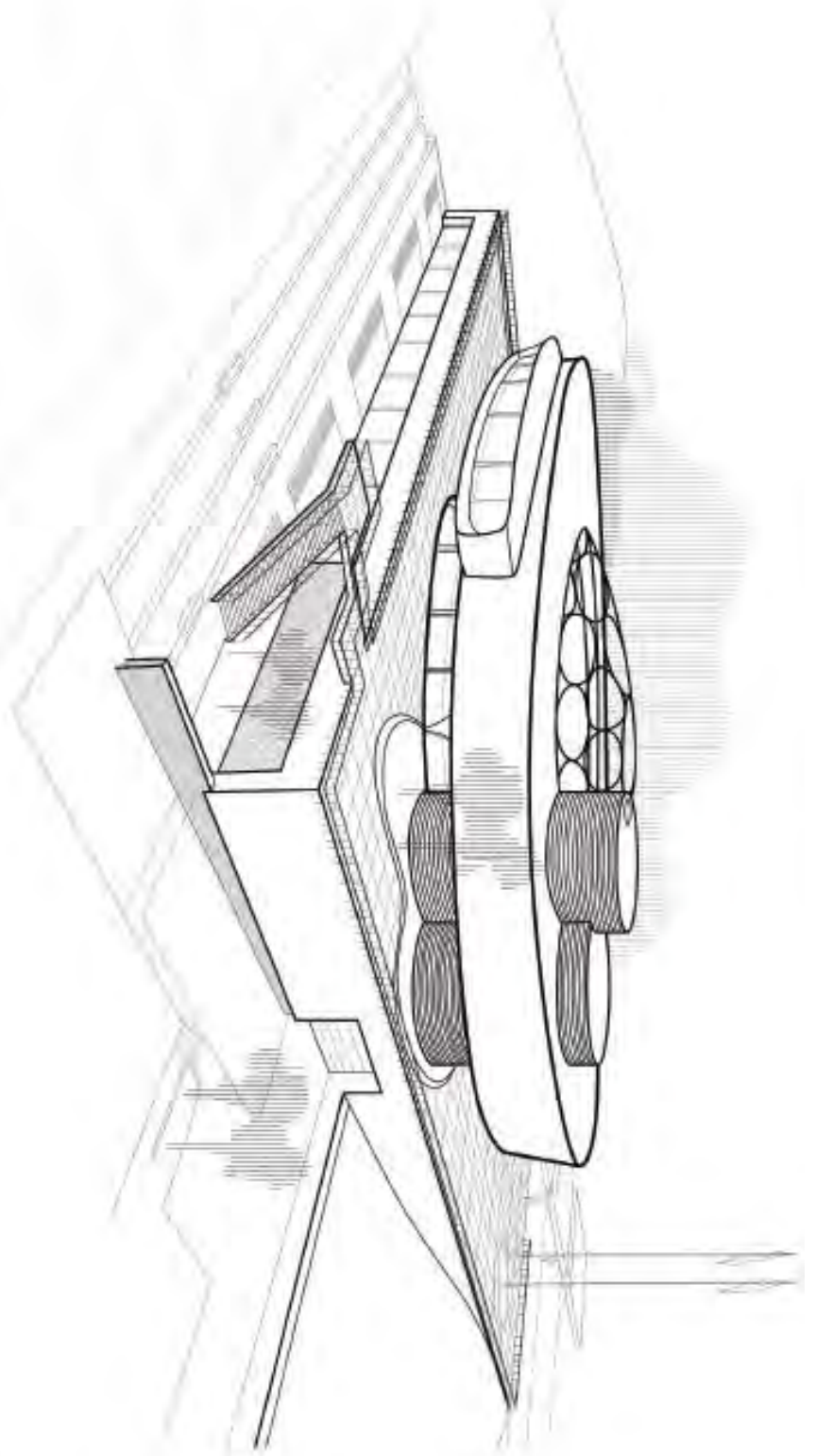

Illustrated by Jeremy Smith,  
**Jack Bialosky Sr.**  



# Center for Leadership Inspire Architecture Group Kids' Home Architecture Camp

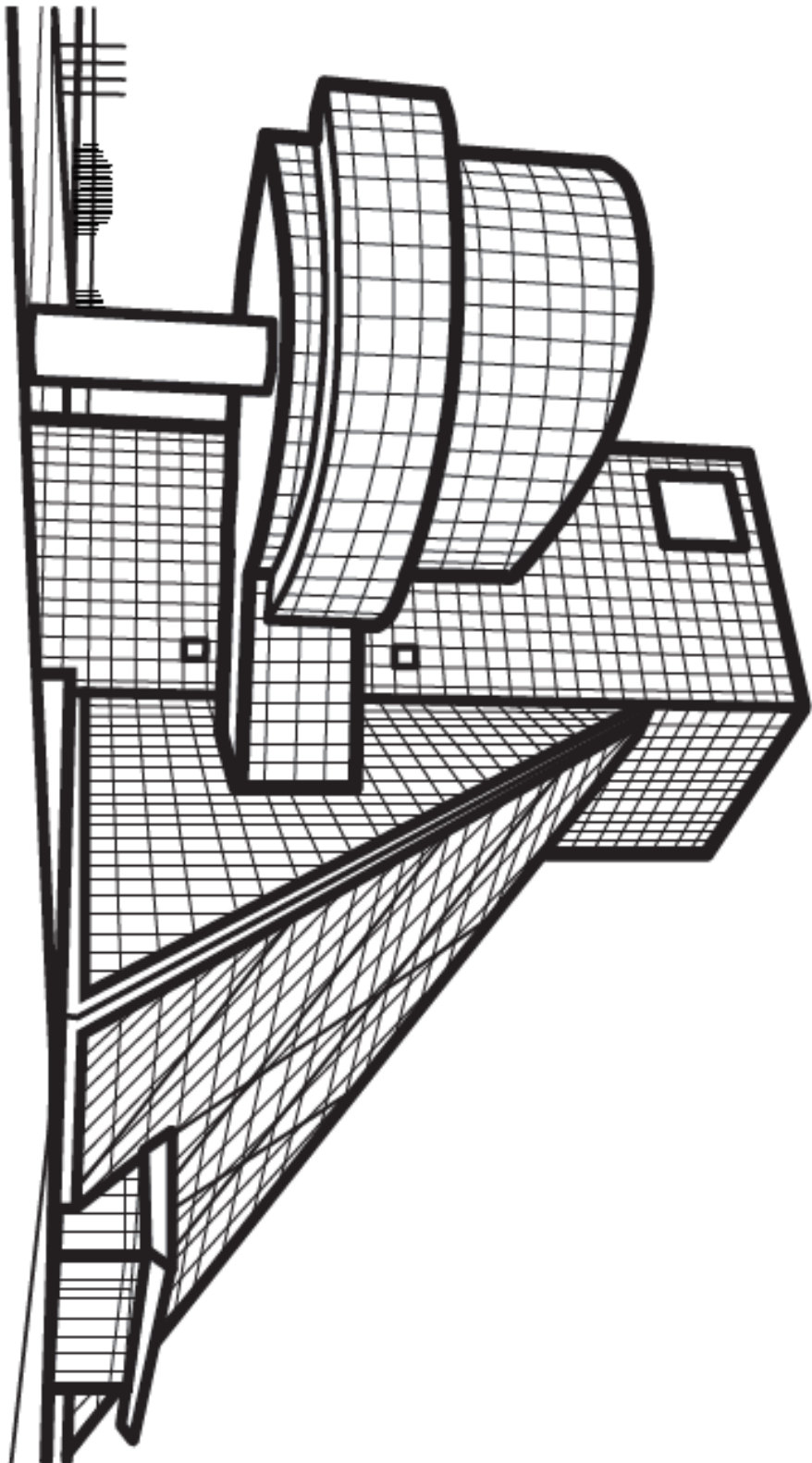

**Rock & Roll Hall of Fame and Museum**  
Cleveland, Ohio  
excerpt from the Cleveland Architecture Coloring Book V.3

illustrated by Jeremy Smith



# Center for Leadership Inspire Architecture Group Kids' Home Architecture Camp

**Akron Art Museum**  
Akron, Ohio  
excerpt from the Cleveland Architecture Coloring Book V.3

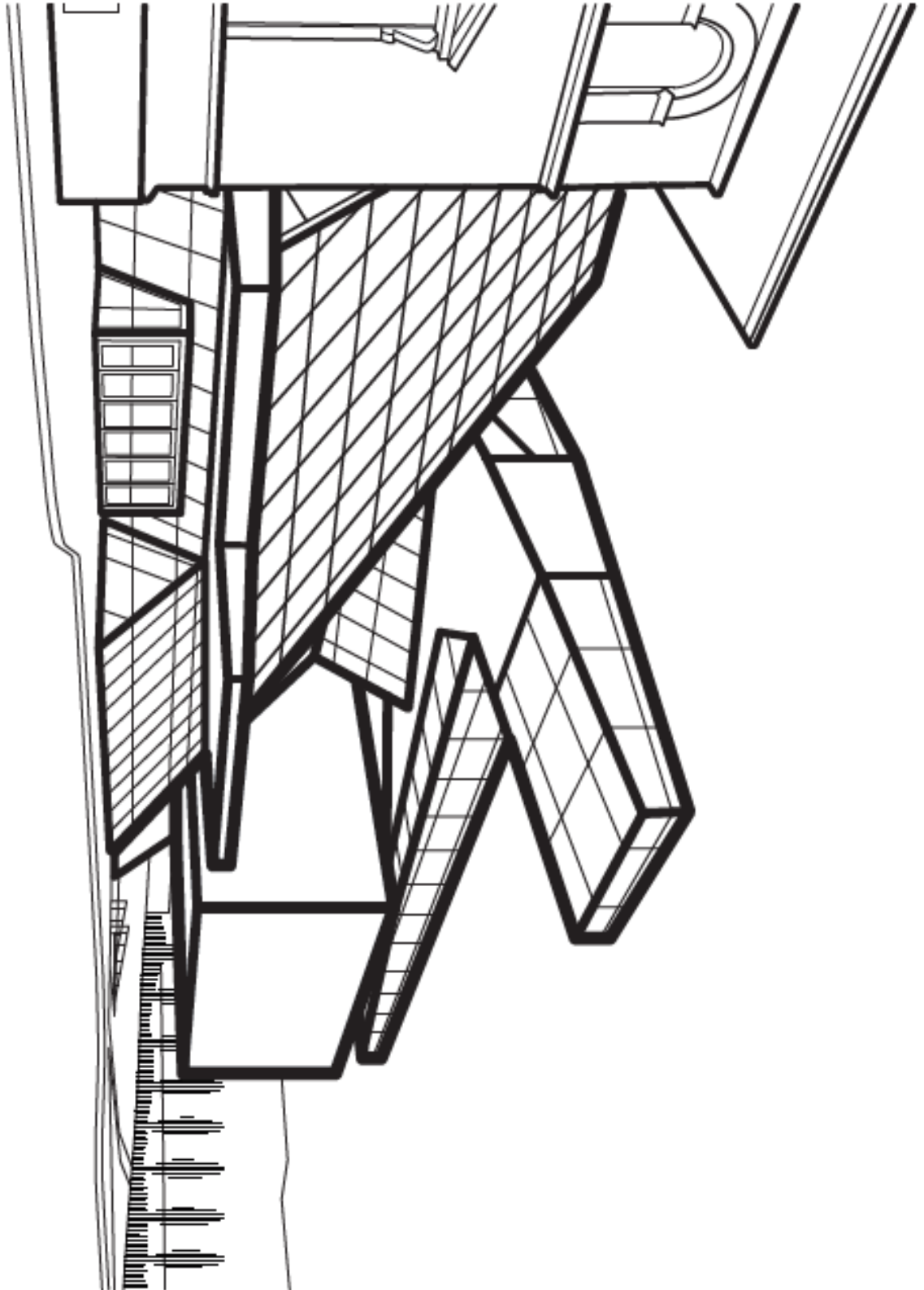

**Coop Himmelb(l)au**  
illustrated by Jeremy Smith



# Center for Leadership Inspire Architecture Group Kids' Home Architecture Camp

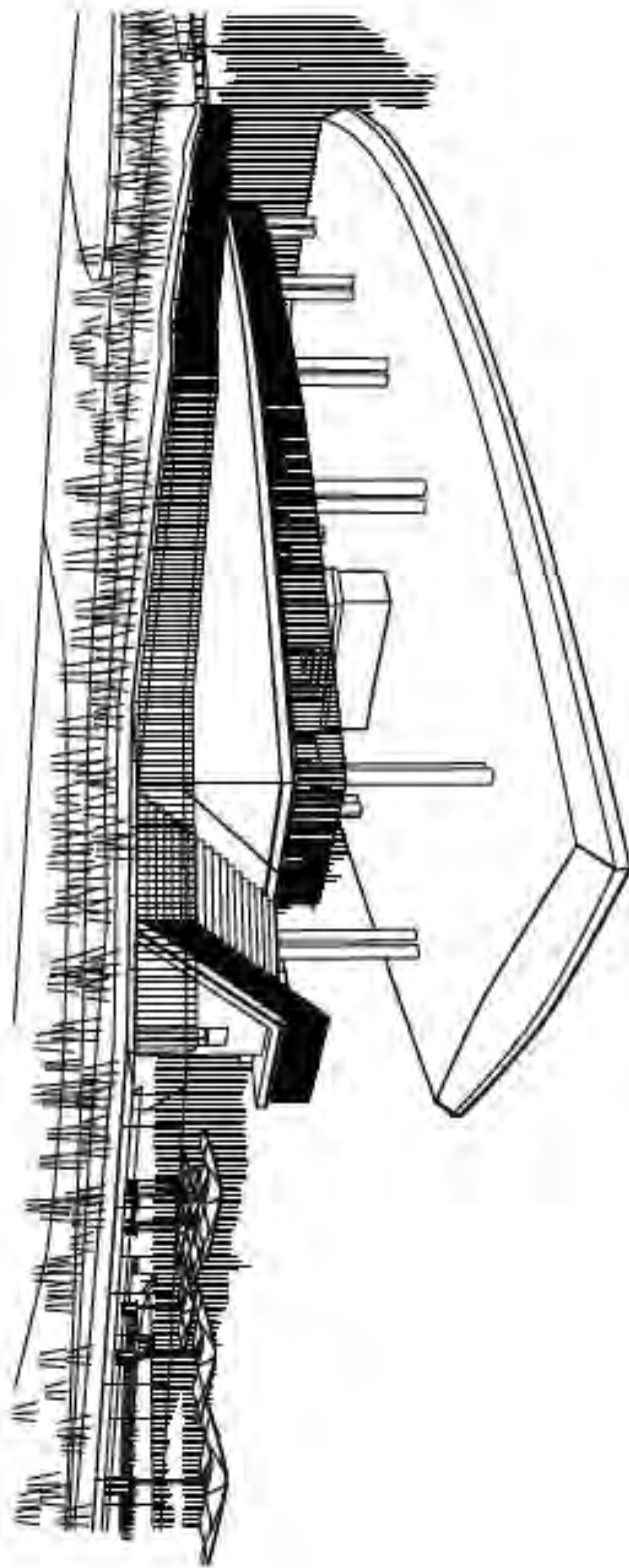

**Edgewater Beach House**

Cleveland, Ohio  
excerpt from *The Cleveland Architecture Coloring Book*, V.1

Illustrated by Jeremy Smith

**Bialosky Cleveland**



# Center for Leadership Inspire Architecture Group

## Kids' Home Architecture Camp

### Section 2: Learning about Architects

#### Lesson:

Architecture is a legacy profession with each generation advancing the work of the last. We learn from the examples those earlier architects provide and we interpret their understanding of the world they designed. It is essential to learn about those former architects and the projects they produced. We need to recognize why they are important and what was their contribution.

#### Activity:

Older students- Select an architect from the following list or choose to investigate one other than those listed. Research the work and significance of the architect selected and produce a report answering several questions. The report, which is to be a minimum of 500 and a maximum of 750 words. The report is to answer the following questions:

1. Who was the architect, when and where did they live and Practice?
2. Why are they important?
3. What were some of their significant works?
4. Why did the student think they are worthy of investigation and what building did you find most interesting?
5. What impact did the architect have on successors?

The student is to create drawings of the building the architect they selected as being the most interesting. These drawings will include:

8. A basic floor plan
9. An elevation of a key view of the building
10. A particular detail that captures the essence of the building (i.e. an entry element, window, a roof element, etc.)

#### List of suggested Architects:

- |   |                                   |
|---|-----------------------------------|
| 1. Sir Christopher Wren                   | 15. R. Buckminster "Bucky" Fuller |
| 2. Inigo Jones                            | 16. Marcel Breuer                 |
| 3. Phillippo Brunelleschi                 | 17. Julia Morgan                  |
| 4. Gian Lorenzo Bernini                   | 18. Zaha Hadid                    |
| 5. Donato Bramante                        | 19. Denise Scott Brown            |
| 6. Thomas Jefferson                       | 20. Jean Gang                     |
| 7. Walter Gropius                         | 21. Kenzo Tang                    |
| 8. Moshe Safde                            | 22. Elizabeth Plater-Zybek        |
| 9. Eric Mendelsohn                        | 23. Louis Henry Sullivan          |
| 10. Antoni Gaudi                          | 24. Robert Robinson Taylor        |
| 11. Charles Renee McIntosh                | 25. Charles Moore                 |
| 12. Charles Eduard Jeneret (Le Corbusier) | 26. Imhotep                       |
| 13. Philip Johnson                        | 27. Mies Van Der Rohe             |
| 14. Paul Revere Williams                  | 28. Moses McKissack III           |

# Center for Leadership Inspire Architecture Group Kids' Home Architecture Camp

Young students- Read to the young children the following Book "10 Architects to Know"

These include:

**Marcus Vitruvius Polio**

**Frank Lloyd Wright**

**Frank Gehry**

**Michelangelo**

**Daniel Liebskind**

**Norma Merrick Sklarek**

**I.M. Pei**

**Andrea Palladio**

**Benjamin Latrobe**

**J. Max Bond**

## 10 Architects to Know

Written and Illustrated by:  
**Judson A. Kline, FAIA**



Center for Leadership  
Inspire Architecture Group  
Kids' Home Architecture Camp

## 10 Architects to Know

### Dedication

This book is dedicated to all of the children who are staying home in an effort to prevent the spread of the Corona-19 virus. It is for my son, daughter-in-law and grand children to provide them a tool for a learning opportunity to expand their young horizons. It is also dedicated to my daughter and wife for their inspiration and support.

## 10 Architects to Know

Marcus Vitruvius Polio  
Michelangelo Buonarroti  
Andrea Palladio  
Benjamin Henry Latrobe  
Frank Lloyd Wright  
I.M. Pei  
Norma Merrick Sklarek  
J. Max Bond  
Frank Gehry  
Daniel Liebskind



# Center for Leadership Inspire Architecture Group Kids' Home Architecture Camp



Vitruvius

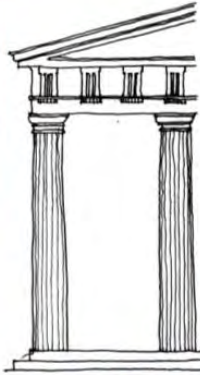

Doric Order

## Marcus Vitruvius Polio

Marcus Vitruvius Polio or Vitruvius, as he is better known, was a first century Roman architect, writer and engineer. He was most famous as the author of a book titled: "De Architectura" or "On Architecture".

In his book, he illustrated principles that continue to teach architects 2100 years later. He introduced the idea that buildings need to be proportioned to the people who use them through his "Vitruvian Man". He also suggested that buildings need to have strength to support themselves, meet the needs of those who will use them and be beautiful to behold.

He also recognized buildings need to be designed and organized according to an order and identified 5 styles of architecture: Doric, Tuscan, Ionic, Corinthian and Composite.



Vitruvian Man

## Michelangelo Buonarroti



Michelangelo

Michelangelo di Lodovico Buonarroti Simoni, best known as Michelangelo was born in Caprese, Italy on March 6, 1475 and died on February 18, 1564. He was among the most influential sculptors, painters and architects of the Italian Renaissance. His creations are impressive and stand as a very important body of work. Amongst those that are regarded for their beauty and importance are the Pieta, The Sistine Chapel and David. His extensive and varied masterpieces make him a true Renaissance Man.



Capitoline Steps  
Rome, Italy



The Pieta, St. Peter's  
Vatican, Italy



The Sistine Chapel  
Vatican, Italy



Laurentian Library  
Florence, Italy



# Center for Leadership Inspire Architecture Group Kids' Home Architecture Camp

## Andrea Palladio

Andrea Palladio was an Italian architect born November 30, 1508 and died August 19, 1580. He was influenced by Roman and Greek architecture. He was a widely influential architect who summarized his teachings in "The Four Books of Architecture". His work in the city of Vicenza has been recognized by the United Nations Education, Scientific and Cultural Organization (UNESCO). Many of his ideas on proportion and detail impact buildings today.



Andrea Palladio



Villa Capra "La Rotunda"  
Vicenza, Italy



San Giorgio Maggiore  
Venice, Italy



Basilica Palladiana  
Vicenza, Italy

## Benjamin Henry Latrobe

Benjamin Henry Latrobe was a British born American architect who lived from May 1, 1764 through September 3, 1820. His career in America was important. He played a role in the design of the United States Capitol and the re-building of the White House following its burning in the War of 1812. As one of the first trained architects in America, he also designed Adena, the home of Thomas Worthington an early governor of Ohio. Today, that home is the focal structure in a development called Governor's Place near Chillicothe, Ohio.

He became the Architect of the Capitol and spent his later years in New Orleans. He has often been referred to as the "father of American Architecture" (1.)



Benjamin Henry Latrobe



The White House  
Washington DC



U.S. Capitol  
Washington, DC



St. John's Episcopal Church  
Washington, DC



# Center for Leadership Inspire Architecture Group Kids' Home Architecture Camp

## Frank Lloyd Wright



Frank Lloyd  
Wright

Frank Lloyd Wright was an American architect born June 8, 1867 and died April 9, 1959. His practice spanned over 70 years producing over 1000 projects with 532 being completed. He believed in designing structures to be in harmony with humanity and the environment, a philosophy he called "organic architecture".

He started what became known as the "prairie school" and also introduced the concept of the "Usonian" home as a vision for an urban style.

He designed many important buildings in the United States and around the world.



Falling Water  
Bear Run, PA



The Robie House  
Chicago, IL

## I.M. Pei



I.M. Pei

Ieoh Ming Pei, FAIA, RIBA was a Chinese-American architect. He was born in Guangzhou, China on April 26, 1917 and died on May 16, 2019. Over the 100 years of his life he completed many important structures in America and around the world. As a principle of the firm Pei Cobb Freed and Partners, he was the lead on projects including the John F. Kennedy Library, the East Building of the National Gallery of Art, the Glass Pyramid of the Louvre Museum in Paris, Bank of China Tower in Hong Kong, Dallas City Hall, the Rock Hall in Cleveland, and many others. He has been the recipient of the American Institute of Architects Gold Medal, the Pritzker Prize and the Nobel Prize in architecture.

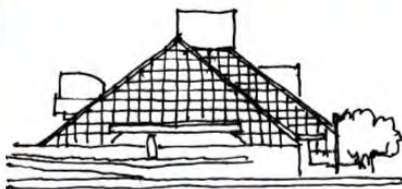

Rock and Roll Hall of Fame  
Cleveland, Ohio

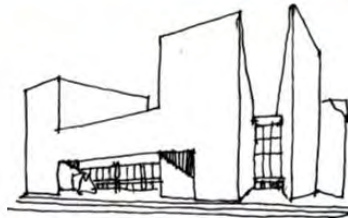

The National Art Gallery Museum  
Washington, DC

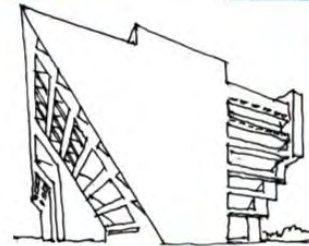

Dallas City Hall  
Dallas, TX



# Center for Leadership Inspire Architecture Group Kids' Home Architecture Camp

## Norma Merrick Sklarek



Norma Merrick  
Sklarek

Norma Merrick Sklarek born April 15, 1926 and passed on February 6, 2012 was a pioneering American architect. She was one of the earliest African American women architects, she became a licensed architect in New York(1954) and California (1962). She was also the first Black woman honored by a Fellowship in AIA (1966 FAIA).

Her skills as a project manager assured the completion of many complex projects. Over her career, she was sought by other female architects for her inspiration and leadership.



Ambassador's Residence  
Tokyo, Japan

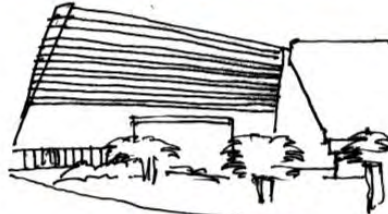

Red Building Pacific Design Center  
Los Angeles, CA

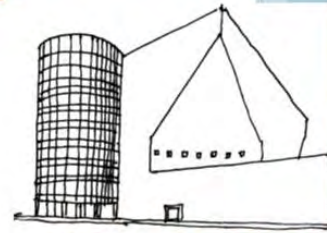

Pacific Design Center  
Los Angeles, CA



J. Max Bond

## J. Max Bond

J. Max Bond was born July 17, 1935 and died February 18, 2009. He was an African American architect and educator. He gained international recognition for his design of the Bolatanga Regional Library in Ghana, Africa. He also contributed to the design of the 9/11 Memorial Museum in New York and the Martin Luther King Center for Non-Violent Social Change in Atlanta.

He served as the chairman of the architecture division at Columbia University Graduate School of Architecture and Planning. He has been an inspiration to generations of minority architects.



9/11 Memorial Museum  
New York, NY



Martin Luther King Center for Non  
Violent Social Change Atlanta, GA

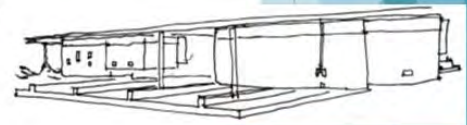

Bolgatanga Regional Library  
Ghana, Africa



# Center for Leadership Inspire Architecture Group Kids' Home Architecture Camp

## Frank O. Gehry



Frank O. Gehry

Frank O. Gehry, FAIA was born in Canada on February 28, 1929 and is an American architect. His works are recognized amongst the most important contemporary architecture in the world. He is a recipient of the American Institute of Architects Gold Medal.

Some of his most recognized work include the Guggenheim Museum in Bilbao, Spain, the Disney Concert Hall in Los Angeles and the Dance House Fred and Ginger in Prague, Czech Republic. He has produced numerous other projects that are both significant and controversial.



Fred & Ginger  
Prague, CR

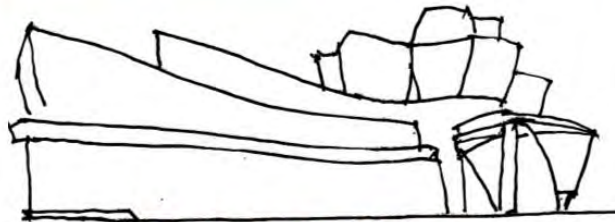

The Guggenheim Museum  
Bilbao, Spain

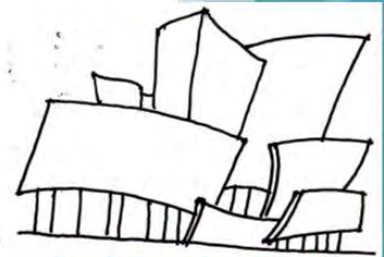

The Disney Concert Hall  
Los Angeles, CA

## Daniel Libeskind



Daniel Libeskind

Daniel Libeskind, FAIA born May 12, 1946 is a Polish, American architect, artist and educator. His work has gained recognition around the world and he has designed many important museums in Berlin, Copenhagen, Denver, Toronto, Manchester, Singapore and Israel. However, one of his most important works came through winning the competition to design the World Trade Center following the attacks of September 11, 2001. He has also designed furniture and produced sculptures. He served as the Director of the Architecture Department at Cranbrook Academy as well as teaching at the University of Kentucky, Yale University and the University of Pennsylvania.



Jewish Museum  
Berlin, Germany



Denver Art Museum  
Denver, CO

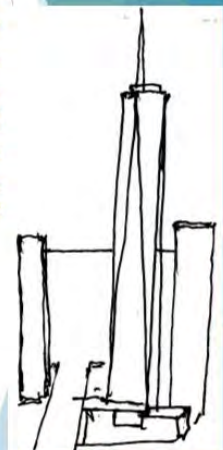

One World Trade Center  
(Freedom Tower)  
New York, NY

# Center for Leadership Inspire Architecture Group Kids' Home Architecture Camp

## 10 Architects to Know

Children are the legacy of these great architects and by knowing them, they will gain a greater appreciation of the built environment and consider how to make it better.

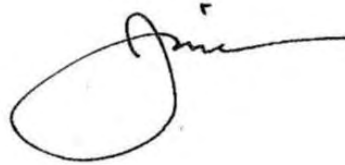

## Drawing Credits/References

All drawings were created by the author.

Written resources include: Wikipedia articles that have been interpreted by the author.

1. *Ravetz, Alison. "Benjamin Henry Latrobe: "Father of American Architecture"". C-SPAN. Archived from the original on 12 December 2013. Retrieved 11 September 2013.*



# Center for Leadership Inspire Architecture Group

## Kids' Home Architecture Camp

Young students- Read to the young children the following Book "10 Important Houses to Know"

These include:

**La Rotunda**

**Robie House**

**Fallingwater**

**Farnsworth House**

**Casa das Canoas**

**Monticello**

**Villa Savoye**

**Aalto House**

**Glass House**

**Gehry House**

# 10 Important Houses to Know

Written and Illustrated by:  
**Judson A. Kline, FAIA**

Center for Leadership  
Inspire Architecture Group  
Kids' Home Architecture Camp

## 10 Important Houses to Know

### Dedication

This book is dedicated to all of the children who are staying home in an effort to prevent the spread of the Corona-19 virus. It is for my son, daughter-in-law and grand children to provide them a tool for a learning opportunity to expand their young horizons. It is also dedicated to my daughter and wife for their inspiration and support.

## 10 Important Houses to Know

La Rotunda  
Monticello  
Robie House  
Villa Savoy  
Fallingwater  
The Aalto House  
Farnsworth House  
The Glass House  
Casa Das Canoas  
Gehry Residence

# Center for Leadership Inspire Architecture Group Kids' Home Architecture Camp

## The Robie House

Frank Lloyd Wright was an American architect who designed the house for the 28 year old Fredrick Robie and his family. Built between 1909 and 1910 the house would become a classic example of Mr. Wright's Prairie School architecture. It now sits on land that is a part of the University of Chicago. Like many of his other projects, Wright designed the interiors and many of the furnishings for the house.

It is both designated a National Historic Landmark and on the National Register of Historic Places. The Robie House is also a World Heritage Site of the United Nations Education, Scientific and Cultural Organization.



The Robie House  
Chicago, IL.

## Villa Savoye

Built in Poissy at the outskirts of Paris, France, the Villa Savoye was designed by Swiss architect Charles-Edouard Jeanneret or Le Corbusier as he is better known. The home was erected as a country retreat for the Savoye family and built between 1928 and 1931. The residence was constructed using reinforced concrete erected on pillars. The house became a well recognized example of the new "International Style". As a champion of modern architecture, Le Corbusier set an example for many to follow. Students came to work and study with him to understand this new vocabulary. In 2016, the Villa Savoye along with other works by Le Corbusier were designated UNESCO World Heritage Sites.

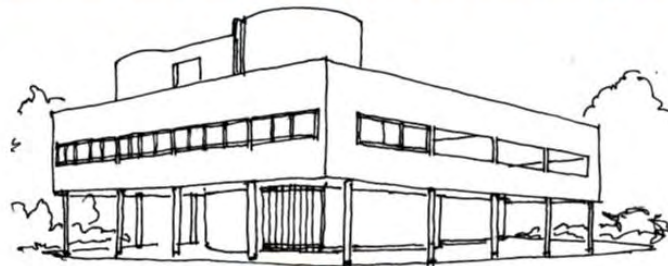

Villa Savoye  
Poissy, France



# Center for Leadership Inspire Architecture Group Kids' Home Architecture Camp

## Fallingwater



Fallingwater  
Bear Run, PA

Located in rural, southwest Pennsylvania, Fallingwater was designed by architect Frank Lloyd Wright for Edgar Kaufmann Sr., who owned Kaufman's Department Stores. Built In 1935 over the Bear Run, the house was constructed to connect to the water, not just look at it from a distance.

It is regarded as one of the prolific, master architect's most important works. People travel from all over the world to witness this masterpiece of environmental connection between building and its surroundings. In 1966 Fallingwater was designated a National Historic Landmark and in 2019, it was included on the World Heritage List.

## Aalto House

The Aalto house was the home of architect Alvar Aalto and is located in Munkkiniemi a suburb of Helsinki, Finland. In 1934, the architect acquired the property and then designed the house which was completed in 1936. The house represented a new style of architecture and also served as the studio for Mr. Aalto's architectural practice. His use of wood as a finish material softened the hard edges and lines of the house. The house has been protected by a law in 1982 and has been renovated and restored by the Finnish Ministry of Education and Culture.

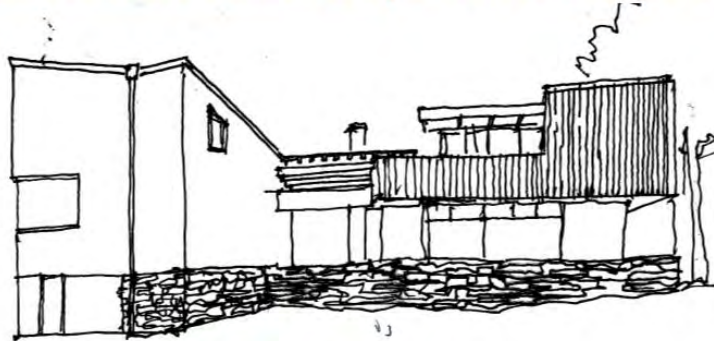

Alvar Aalto House  
Helsinki, Finland

# Center for Leadership Inspire Architecture Group Kids' Home Architecture Camp

## Farnsworth House

The Farnsworth House was designed and constructed by Ludwig Mies van der Rohe between 1945 and 1951. It was a rural retreat for Dr. Edith Farnsworth and her family in Plano, Illinois about 55 miles southwest of Chicago on an estate adjoining the Fox River. The construction began in 1950 and completed in 1951. Mies, as the architect is known, also served as the general contractor for the project. The architect did not complete the project due to a dispute with Dr. Farnsworth. The project was completed by architect William Dunlap, a former employee of Mr. van der Rohe. It has been recognized as an example of the International style and was placed on the Register of Historic Places in 2004 and designated National Historic Landmark in 2006.

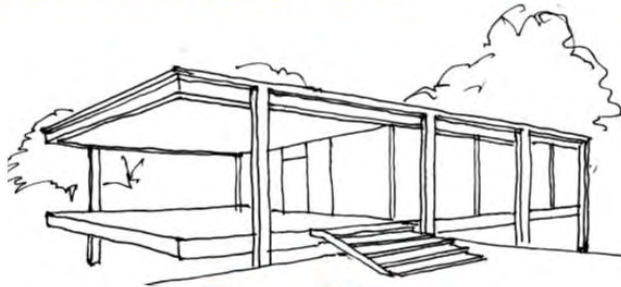

Farnsworth House  
Plano, IL

## The Glass House

The Glass House was designed and built between 1948 and 49 by architect Phillip Johnson, FAIA in New Canaan, Connecticut. It was built as the architect's own residence. It exemplified a minimal structure and geometry. While the transparency of the building have brought it both acclaim and criticism, it sits behind a stone wall that hides the views into the house from the street. It utilized industrial materials in a residence. It was designated a National Historic Landmark in 1997 and is now owned by the National Trust for Historic Preservation.

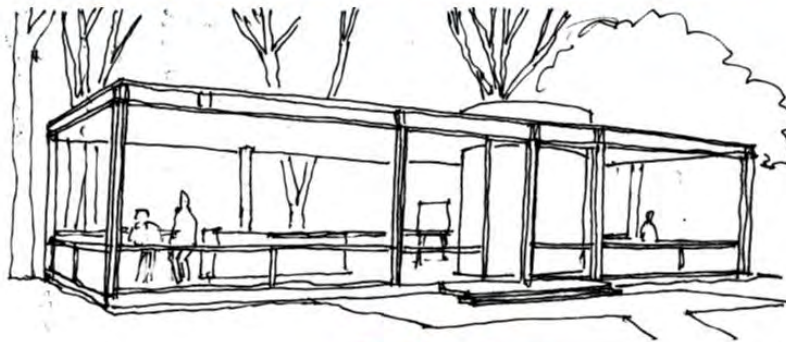

The Glass House  
New Canaan, CT



# Center for Leadership Inspire Architecture Group Kids' Home Architecture Camp

## Casa das Canoas

Designed by architect Oscar Niemeyer in 1951 to serve as a family home, Casa das Canoas is among the most significant works of modern architecture in Brazil and the world. In his design, the architect merged the ideas of minimalism with organic architecture to create a simple and powerful design. Like Philip Johnson's glass house, this structure draws from Mies van der Rohe's Farnsworth house.

The house is located in Canoas, in Barra de Tijuca, a suburb of Rio de Janeiro.



Casa das Canoas  
Rio de Janeiro, Brazil

## Frank O. Gehry House

Frank O. Gehry, FAIA designed and built his home in 1977 when he purchased a Dutch colonial style house and decided to build around the existing structure. He explored the use of industrial materials utilizing metal, plywood, chain link fencing and wood framing to investigate new forms and connections in re-imagining this house. It created a great deal of controversy in the neighborhood for its brash forms and unconventional materials. As of 2016, the house is still owned by Frank Gehry, who plans to keep it in the family.



Frank O. Gehry House  
Santa Monica, CA



Center for Leadership  
Inspire Architecture Group  
Kids' Home Architecture Camp

## 10 Important Houses to Know

Through the study of these important houses, children will appreciate the legacy they have been provided. By knowing these homes, they will gain a greater appreciation of the built environment and have examples to consider in learning how to make it beautiful.



## Drawing Credits/References

All drawings were created by the author.

Written resources include: Wikipedia articles that have been interpreted by the author.

# Center for Leadership Inspire Architecture Group Kids' Home Architecture Camp

## Section 3: Learning about Design

**Lesson and Activity for older students:**

### Design project

At the core of the architect's activities and skills is the creation of spaces for human activity and the organization of forms these spaces will take. No architectural investigation would be complete without undertaking the design process. The student will be given a program of project requirements and an opportunity to create their own expression of the structure that would facilitate those requirements. The student will have an opportunity to explore the sequence of the design process in an abbreviated format using the skills gained through the previous exercises.

The design project will be based upon creating a museum or an experience with limited gallery, activity or exhibition space to house and display the elements or artifacts connected with the idea for the facility. It should reflect the character of the designer and consider how elements such as light and orientation affect the display and activities.

The program will include the following elements (student to determine how large each may want to be and the relationship to each other):

1. Program:
  - a. Three gallery spaces
  - b. Office area including: space for a curator, administrator, conference area, storage of supplies, mail room, copy area and security office
  - c. Entry area gathering space
  - d. Retail store
  - e. Storage and work area to receive and prepare works for display
  - f. Coat room
  - g. Kitchen for catering events
  - h. General storage
  - i. Restrooms (separate for men and women)
  - j. Reception/information desk

### Design Process Steps

# Center for Leadership Inspire Architecture Group Kids' Home Architecture Camp

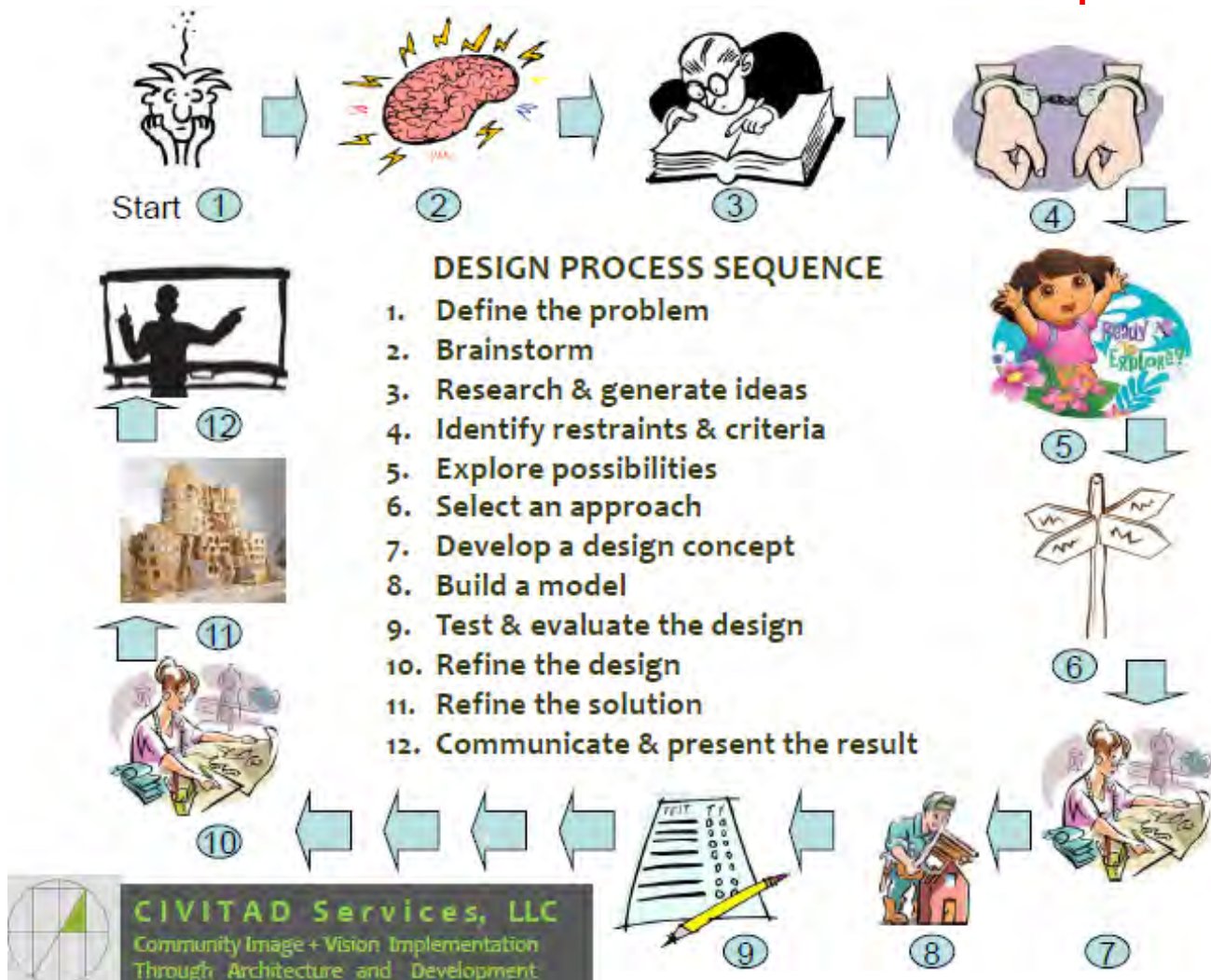

## 1. Investigative study

The design study of the architectural project is an investigation of precedent and historic experience applied to a new circumstance or problem. As architects prepare themselves through studying the work of their predecessors along with investigating the conditions influencing a particular project, the examination of similar works and learning about the typology of buildings and spaces used for this activity is essential. In order to have a frame of reference, it is appropriate to begin the process by considering other architects, their works, their styles, how they treated form and function in this type of project. Referring back to the architect investigated in the first part of the program, look into projects the architect may have undertaken in this building type. Contrast how the architect arranged spaces and created forms in the development of the architectural vocabulary they use in their work. Also look at other buildings of similar type to understand the forms and relationships which may be appropriate for the student's own project.

- a. Research how other architects approached this type project using articles from available books.
- b. Examine other building styles which may be appropriate as background to the design using magazines and articles.

# Center for Leadership

## Inspire Architecture Group

### Kids' Home Architecture Camp

- c. Examine those influences affecting the design of the student's museum
- d. Consider a theme that sums up their work and may result in a form for the building.
- e. Prioritize the project elements and develop the understanding of the relationships between the program components in a written form.
- f. Create a design analysis of the project program elements of how the puzzle pieces may fit together based upon the prioritization noted and the influences determined.

#### 2. Design study

Design development is the central activity undertaken by the architect; from it all other activities are derived. The process for evolving the design is essential to this endeavor. Through the design exercise, the student will have the opportunity to explore the process of generating a project. This activity takes place in creating informal plan and view sketches.

- a. Organize the program elements into a plan for the project expressing the theme suggested based upon the investigative priorities, influences, connections, and preferences,
- b. Develop an envelope (enclosure) which will give form to the plan.
- c. Solicit input from the mentor team in critique of the project concept and refine the design
- d. Evolve a concept drawing which depicts the size, scale, relationship and form of the project.

#### 3. Presentation Development

The communication of the conceptual idea requires the use of media to record and identify the project components and express the design so others can understand and appreciate it. This is done through the production of drawings and sketches which depict the intent of the design.

- a. Prepare specific drawings which clearly describe the concept based upon the design sketches produced in the previous phase of the project.
  1. Floor plan with dimensions
  2. Elevation (draw all four sides) with dimensions and suggestions for material
  3. Prepare a perspective sketch view of the building
- b. Prepare any other information (i.e. material samples) either written or drawn to help communicate the ideas the design will suggest.

#### 4. Formal Presentation (included within the time frame of the drawing component)

- a. Student will meet with the mentor team
- b. Student to display and present the drawings and describe their understanding of the elements of the space.
- c. Student will have an opportunity to get input from the mentor team
- d. Student will learn how to defend their ideas or discuss alternatives based upon critique.

#### 5. Conclusion

At the completion of the program and evaluation of the student, the student has the opportunity to describe what they learned, how the program helped better understand the profession, practice and preparing of an architect, what could be improved and the student's feelings about architecture after having had this experience.



# Center for Leadership Inspire Architecture Group Kids' Home Architecture Camp

## Lesson and Activity for younger students:

### Design project

At the core of the architect's activities and skills is the creation of spaces for human activity and the organization of forms these spaces will take. Exploring architecture is completed through the design process. Young students can investigate the interrelationship of shape, color, organization and form in creating their own idea for a building. They can choose to create a building, plan or an urban landscape in this exercise.

#### Materials needed

- 8 ½ X 11 Colored paper, multiple sheet
- 11 X 17 background drawing paper
- Scissors
- Glue/tape
- Crayons/colored pencils

#### Activity Procedures

11. Cut out various geometric shapes from different colored paper
12. Squares
13. Rectangles
14. Rhomboids
15. Parallelograms
16. Triangles
17. Circles
18. Ellipses
19. Have children add color, detail, patterns and shapes to the colored paper elements.
20. Instruct the children to imagine they are the architect for a building or a city and they should organize the colored forms into a building or a city scape on a larger background paper.
21. Once they are satisfied with the organization, help them glue or tape down their project.
22. Add detail to the background paper with crayons or colored pencils.
23. Have them give it a name and describe who would use it-make up a story to go with it.
24. Alternatively, organize the shapes into a building plan where each shape is a room. They will then connect the rooms to each other to produce a plan. Continue on with steps 4, 5 and 6.

## Section 4: Building Models

### Lesson and Activity for older students:

# Center for Leadership Inspire Architecture Group Kids' Home Architecture Camp

Architects often build models of the buildings they design. These are used to:

25. determine the massing and proportion of the building;
26. resolve elements to make sure they work in the built form;
27. provide the client and others an idea of the finished project;
28. promoting the project; and
29. identify areas where further study may be required.

Cultivating the skills required to be a competent model builder can be valuable in exploring architecture. In this segment, there are two tasks and explorations. The first is the building of a model of an architecturally significant structure. The students can go to an internet site that includes templates for the buildings along with instructions on how to build them. The site is Creative Park by Cannon where models can be downloaded from: <https://creativepark.canon/en/categories/CAT-ST01-0097/index.html>

The second is to explore the structure, understand the history and architect who created it. In this activity, a brief report of no more than 500 words should be written and include the following information:

1. The name
2. Location
3. Dates of construction
4. The architect
5. The significance of the building
6. Why you find it interesting

As an alternate to downloading the templates from the noted site, students could create their own model templates and then using, crayons, colored pencils or markers decorate the stretched out model and put together their structure. Refer to example below.

The model depicted below is of the Lewin Residence erected in 1928 in Berlin-Zelendorf, Germany. It was designed by Walter Gropius, one of the leaders of the Bauhaus, a school for art, architecture and design. It gained recognition for the modern movement in pre-World War Two Germany. It was significant in developing a new design vocabulary for architecture in the mid-twentieth century. The clean lines, simple forms and extensive use of glass introduced a new design style that would change contemporary architecture for years to come.



# Center for Leadership Inspire Architecture Group Kids' Home Architecture Camp

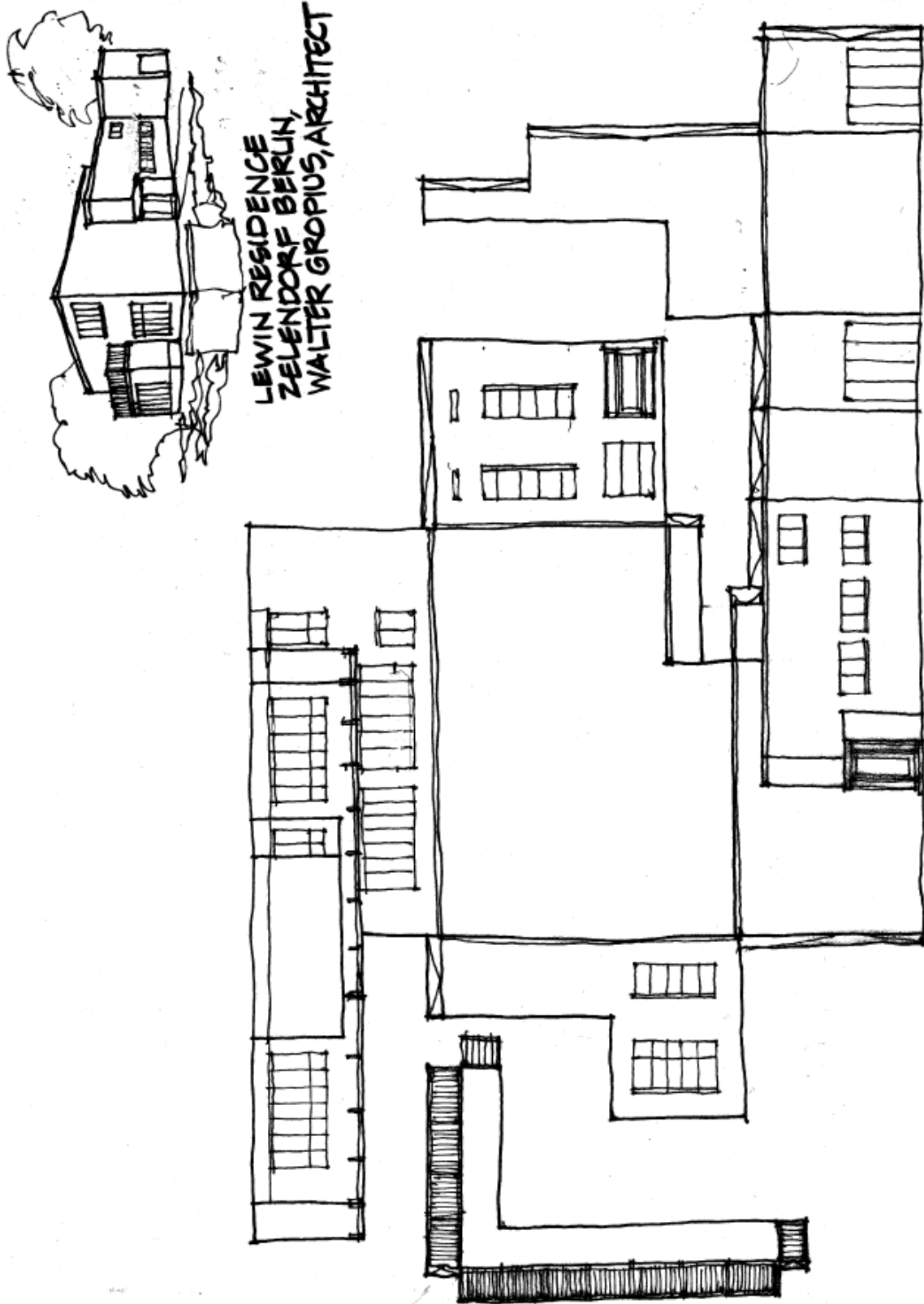

# Center for Leadership Inspire Architecture Group Kids' Home Architecture Camp

Lewin House Cut Out and Assembly Instructions:

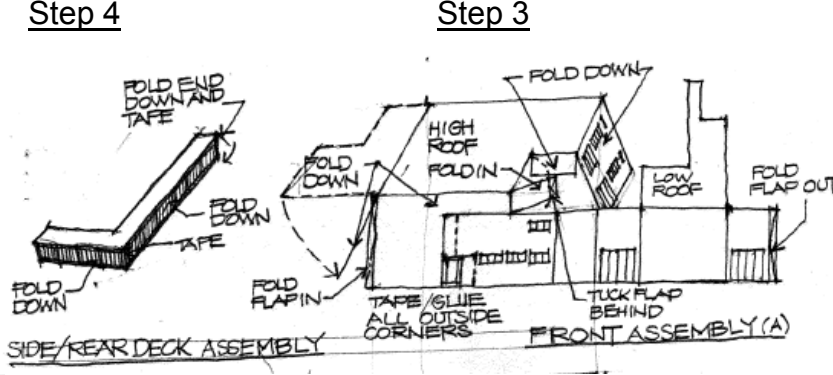
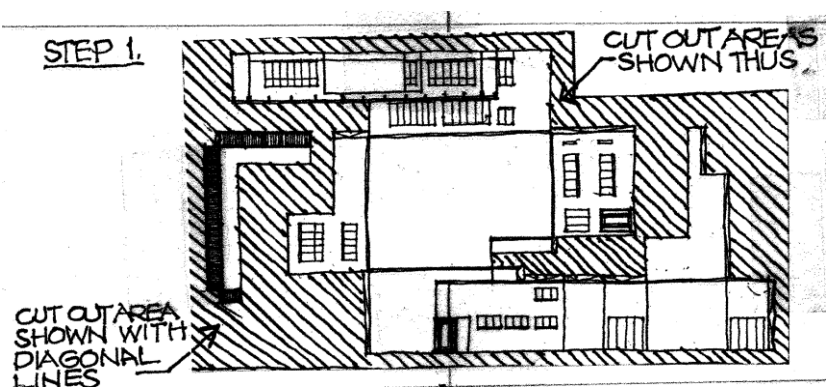
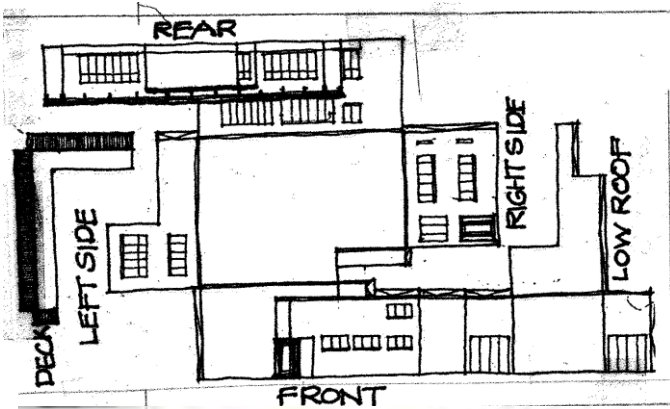

Step 8

Step 7

Step 6

Step 5

Step 9

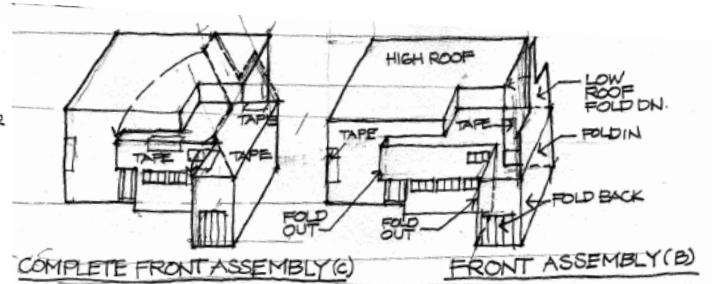
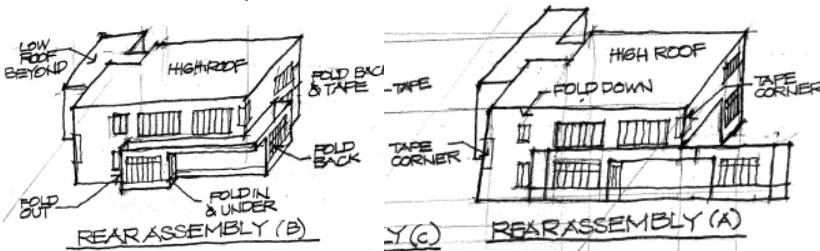

Step 9

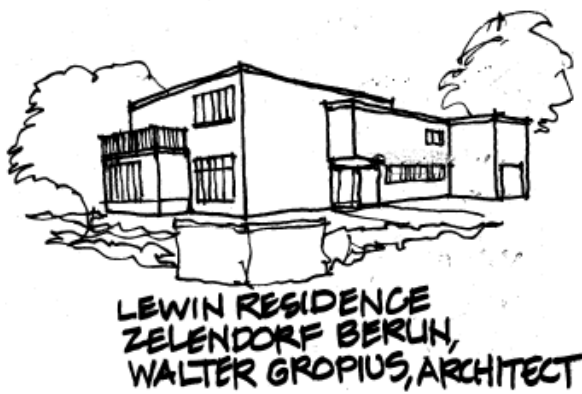

Lewin House Model  
Complete-Front View

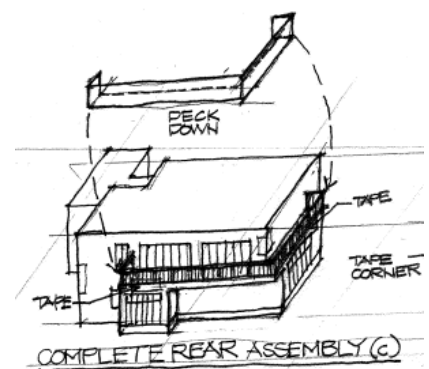

Lesson and Activity

for younger students:

# Center for Leadership Inspire Architecture Group Kids' Home Architecture Camp

Parents or Teachers should cut out the following template shapes and allow young students to decorate them and fold into shapes. Assemble with tape. (images provided courtesy of Ray Beeler and AIA Westchester Hudson Valley)

## House Shape

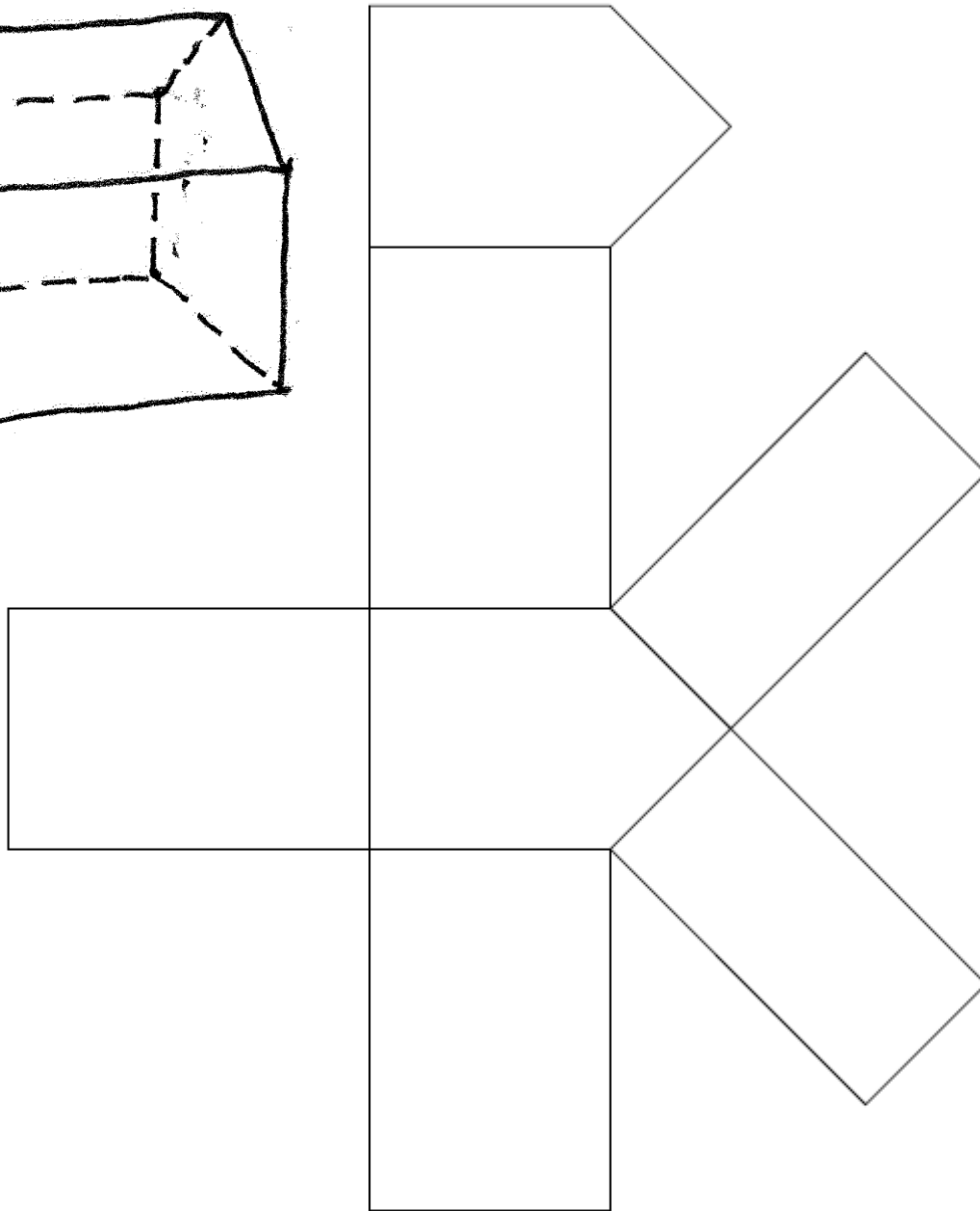
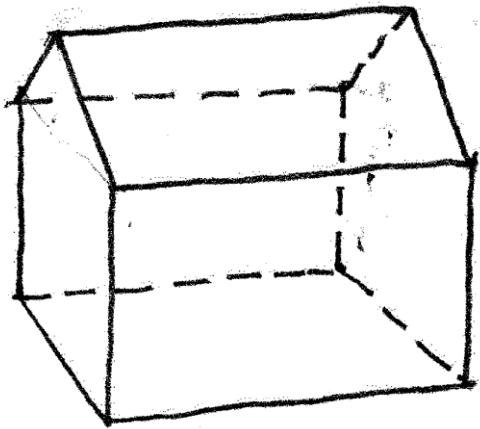



# Center for Leadership Inspire Architecture Group Kids' Home Architecture Camp

## International Style Box House

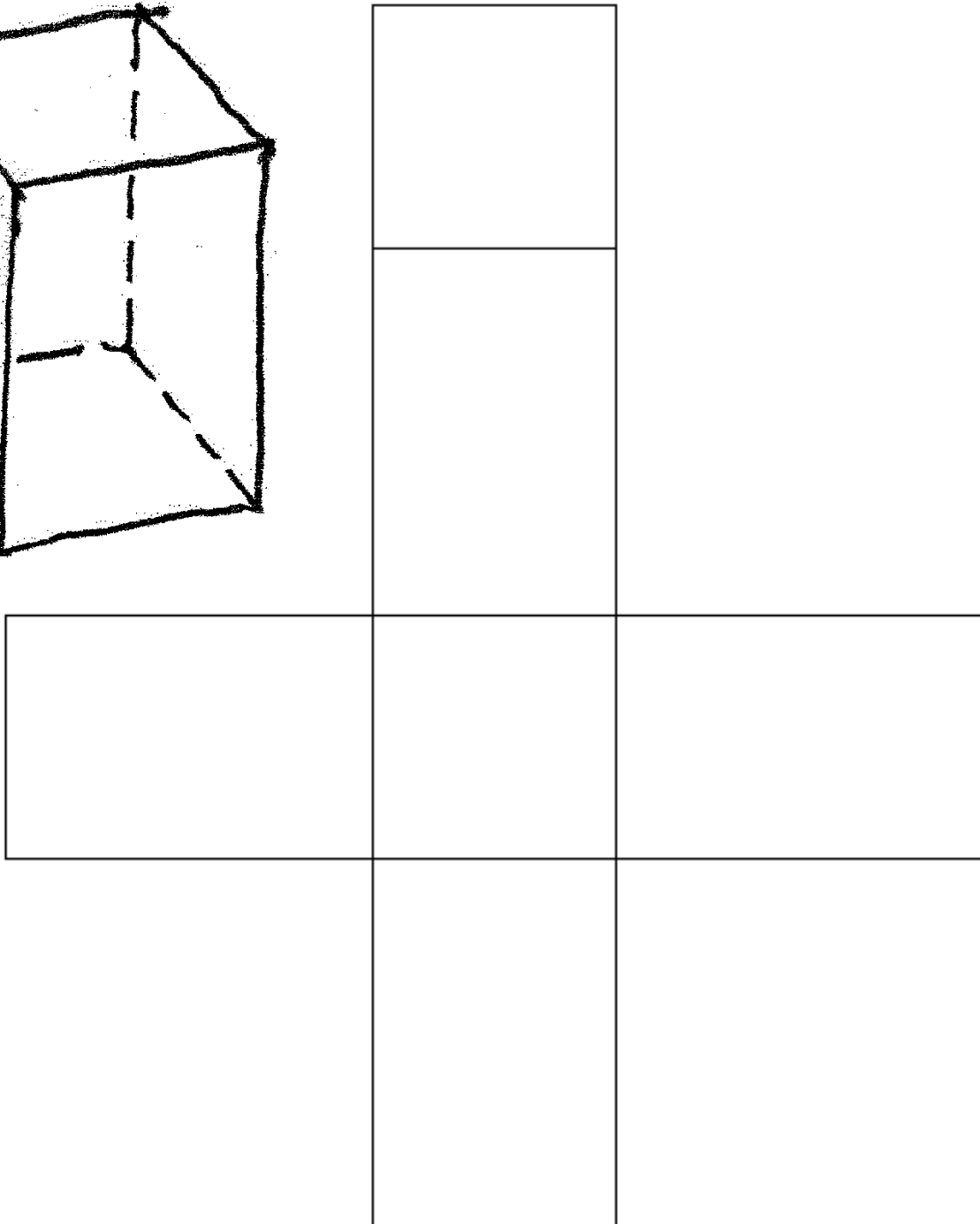
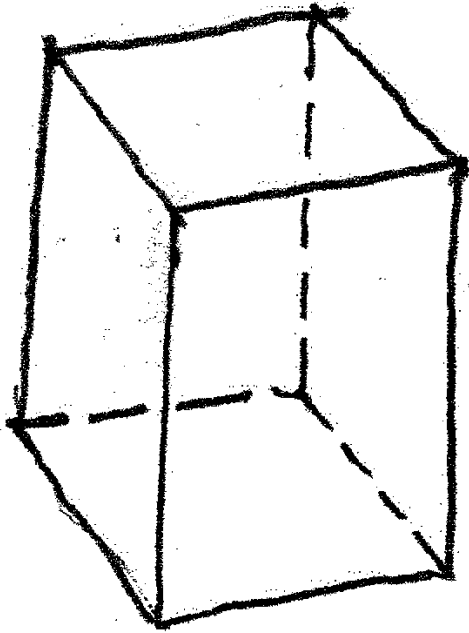

## Obelisk Form

# Center for Leadership Inspire Architecture Group Kids' Home Architecture Camp

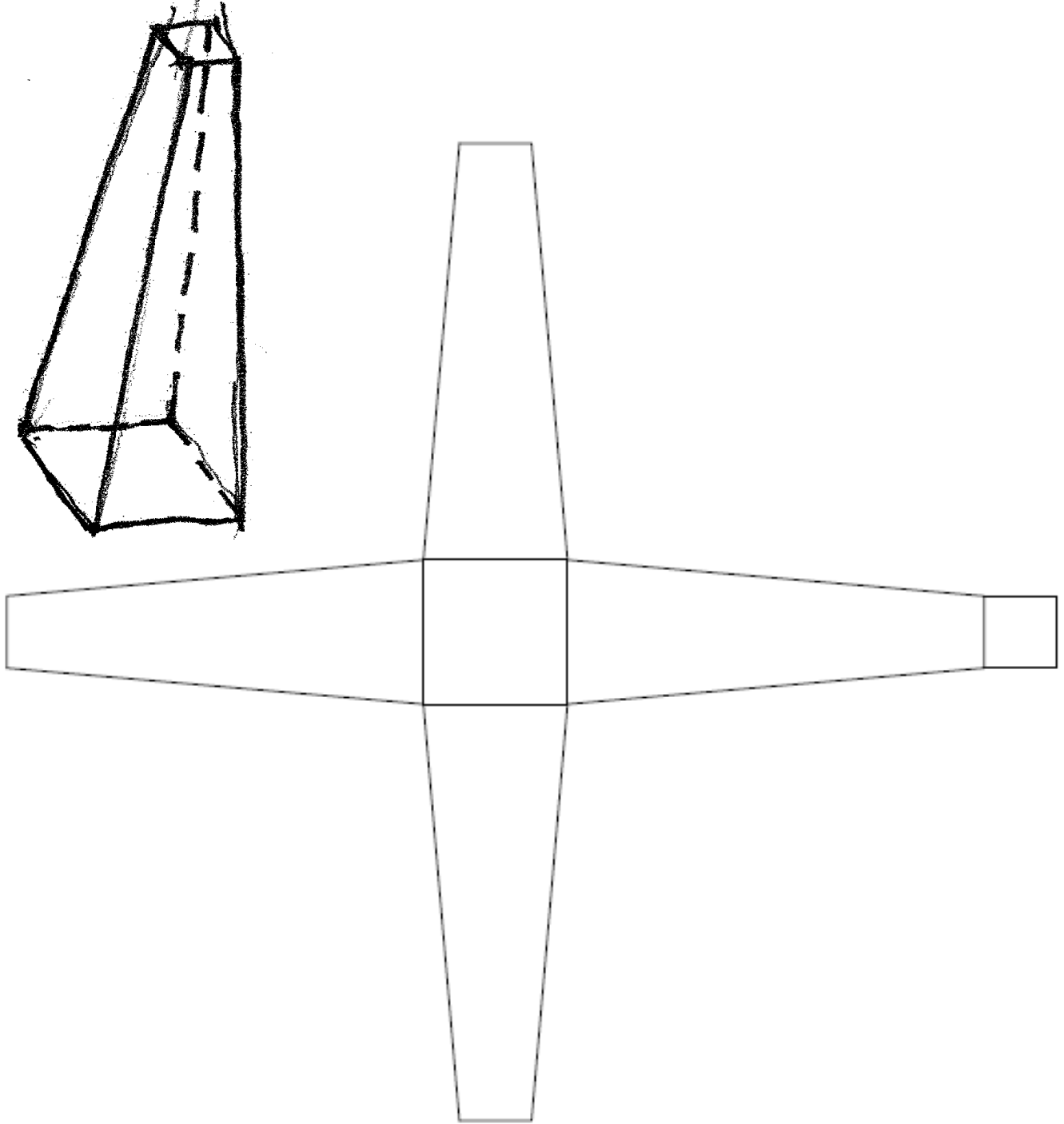

# Center for Leadership Inspire Architecture Group Kids' Home Architecture Camp

## Section 5: Principles of Structures

Lesson and Activity for older students:

### Lesson:

In his important literary work, Vitruvius, a first century Roman architect, writer and engineer, wrote that buildings must meet three simple criteria. In Latin he proclaimed "Firmatos, Utilitas, Venustas", translated these are structural strength, meet their purpose and be beautiful. First, buildings need to meet the requirements to be able to stand up to the forces that would impact them. Therefore, structural principles are essential to understand how buildings are supported.

One of the fundamental principles of structure is the triangle as universally strong geometric form. When we look at buildings we often find them used in many forms such as trusses and space frames. The great architect, R. Buckminster Fuller, or Bucky, as he is known to many in the field, went so far as to use the tetrahedron or three-dimensional triangle to develop the geodesic dome. A structure seen at Disney World's Epcot Center, amongst other places. He saw this form as being very light and very strong.

We will take a brief look at these structural elements and then engage in an activity to demonstrate how you might design a span to support a weight.

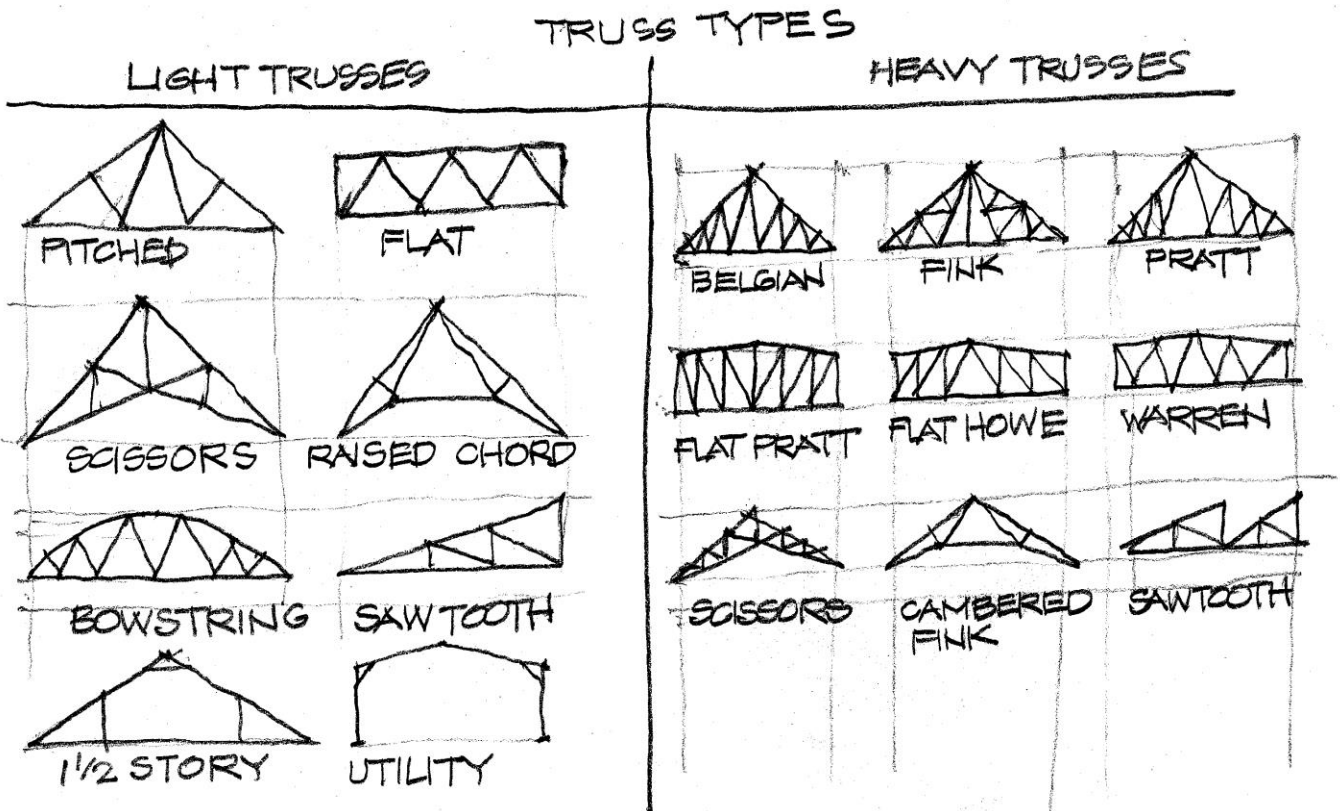



# Center for Leadership Inspire Architecture Group Kids' Home Architecture Camp

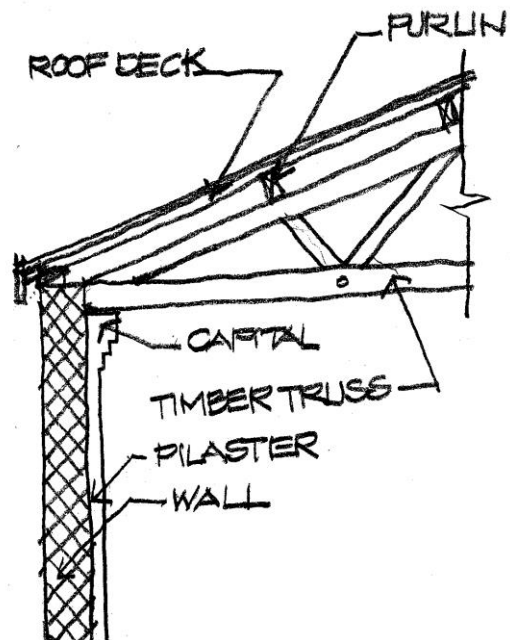
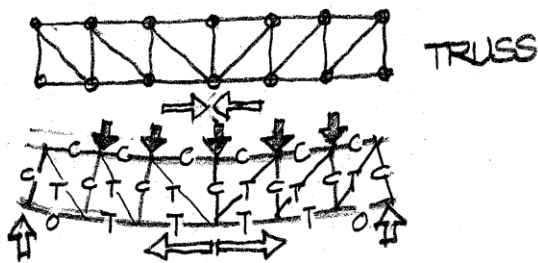
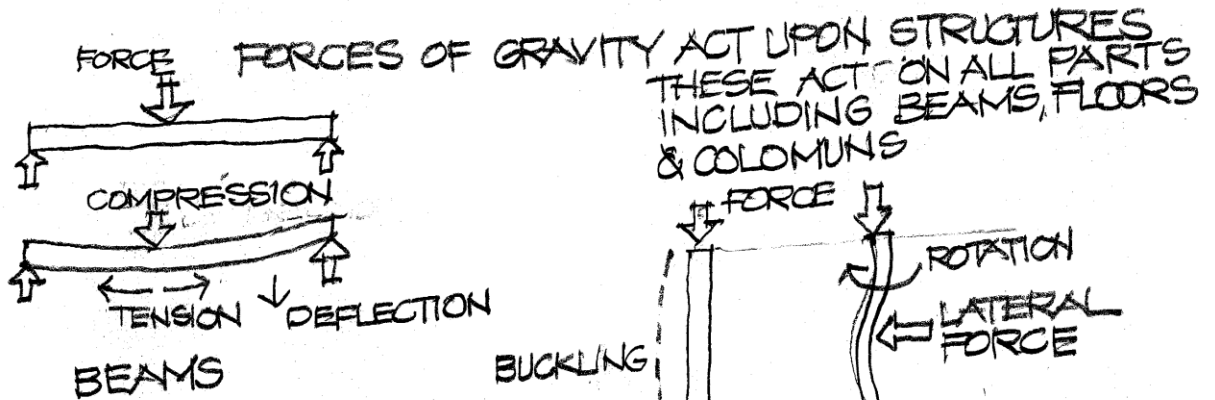
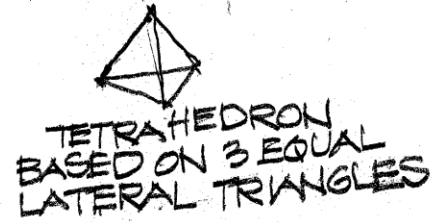
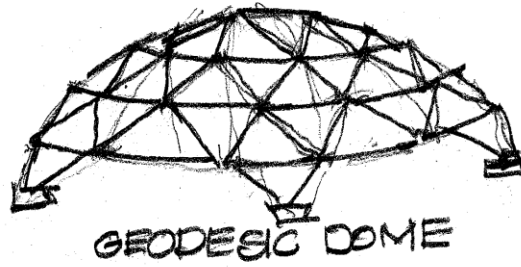

Wall Roof Intersection  
Detail

# Center for Leadership

## Inspire Architecture Group

### Kids' Home Architecture Camp

#### Activity for older students:

Creating a structural model using household materials is a great way to explore the student's ability to design a system to support a specific load over a given distance.

Material required: roll of scotch tape  
80 strands of standard spaghetti  
2 pieces of construction paper/note paper

#### Instructions:

30. Break each strand of spaghetti into 3 equal pieces.
31. Bundle the spaghetti into groups of 3 sections and wrap with a small piece of tape in the middle (there should be 80 bundles).
32. Using the spaghetti bundles and the tape create a bridge that will be at least 12" between points of support.
33. Using the tape, bind the spaghetti bundles to create a structure for a bridge (be creative and utilize the knowledge gained from the lesson).
34. Fold the construction paper to create a roadway the width of your bridge.
35. Guess how much weight the bridge will support (write it down)?
36. Test your bridge by adding weight (find elements of known weight from the kitchen cabinet to determine the strength) at the mid-point between the two supports.
37. How much did it support?
38. Where did it fail?

#### "Thick as a book" exercise:

Using only one piece of 8 1/2 X 11 paper develop a solution to the challenge of elevating a book a minimum of 2" above a table top. No tape or any other material is allowed to accomplish this feat. Be creative! If you find a quick solution, see if you can generate additional solutions that are either derivative of the initial one or novel altogether. There are multiple solutions.

(For the answer e-mail me at: [jkline@civitaservices.com](mailto:jkline@civitaservices.com).)

#### Activity for younger students:

Draw a picture of a bridge and make up a story about the bridge. Who uses it? Where does it go? What materials would you use to build it? Design a second bridge that is totally different than the first one you created.

# Center for Leadership Inspire Architecture Group

## Kids' Home Architecture Camp

### Section 6: Learning About Important Architecture

#### Lesson

Architecture is defined by the precedents (those that came before) with each generation advancing the work of the last. We learn from the examples those earlier structures provide and we interpret the understanding of the world they were designed to accommodate. We gain new technologies that allow for new forms to emerge. Therefore, it is essential to learn about those earlier buildings to understand their influence today. We need to recognize why they are important, what was the impact they have had on society and how they have influenced successor styles.

#### Activities

Older students- The Architecture Research Project is a successor to the Architect research project. This project will focus on buildings instead of people.

39. Investigate the building including providing its history, the architect(s) responsible for it, where it is located, who was the client and what was its purpose?
40. Indicate why you find this building of interest.
41. Provide images depicting the structure. (Extra credit of 5 pts. per drawing if you produce your own drawings) embed these images in your paper.
42. Provide credits and references for information contained in the article.
43. The article shall be no less than 500 words and no more than 750 Words.
44. Select a building of interest to you or one from the following list:

**Taj Mahal**  
**La Pedrera**  
**Burg Khaliffa**  
**The Bath Crescent**  
**Guggenheim Museum Bilbao**  
**Westminster Abbey**  
**Glasgow School of Art**  
**Dancing House**  
**Harpa Concert Hall**  
**Empire State Building**  
**Peterhof**  
**Seagram Building**

**Patronas Towers**  
**TWA Terminal New York**  
**The Dome of the Rock**  
**Himeji Castle**  
**Notre Dame**  
**Fountain Bleu**  
**St. Basil's Cathedral**  
**Heyder Alyev Center**  
**Chrysler Building**  
**Beth Sholom Temple**  
**Unite d' Habitation**  
**Johnson Wax Bulding**

Young students- Read to the young children the following Book "10 Significant Buildings to Know" These include:

**The Parthenon**  
**Angkor Wat**  
**IL Duomo**  
**St. Peters Basilica**  
**La Sagrada Familia**

**Neuschwanstein**  
**Barcelona Pavilion**  
**Guggenheim Museum, New York**  
**Notre Dame du Haut**  
**Sydney Opera House**



Center for Leadership  
Inspire Architecture Group  
Kids' Home Architecture Camp

**10 Significant Buildings  
to Know ©**

Written and Illustrated by:  
Judson A. Kline, FAIA

April 5, 2020

**10 Significant Buildings  
to Know**

**Dedication**

This book is dedicated to all of the children who are staying home in an effort to prevent the spread of the Corona-19 virus. It is for my son, daughter-in-law and grand children to provide them a tool for a learning opportunity to expand their young horizons. It is also dedicated to my daughter and wife for their inspiration and support.

# Center for Leadership Inspire Architecture Group

## Kids' Home Architecture Camp

# 10 Significant Buildings to Know

The Parthenon

Angkor Wat

IL Duomo

St. Peters Basilica

La Sagrada Familia

Neuschwanstein

Barcelona Pavilion

Guggenheim Museum

Notre Dame du Haut

Sydney Opera House

## The Parthenon

The Parthenon is located atop the Athenian Acropolis and was dedicated to the Goddess Athena who was considered the patron of Athens, Greece. Construction began in 447 BC and was completed in 438 BC. It is amongst the most recognized surviving buildings of classical Greece. The architects were Iktinos, Caliorates and Phidias, a sculptor who contributed to the design. The building is a great example of the Doric Order of Architecture. It has also been a church and a mosque. Since 1975, the Parthenon has been a large scale restoration project. In 1987 it was dedicated as a World Heritage Site as an element of the Acropolis.

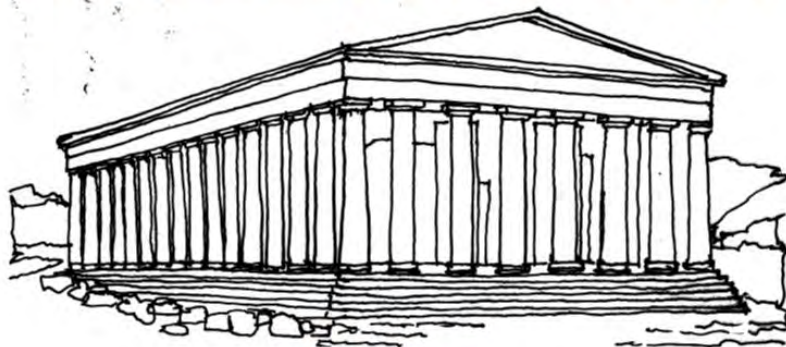

The Parthenon  
Athens, Greece



# Center for Leadership Inspire Architecture Group Kids' Home Architecture Camp

## Angkor Wat

Angkor Wat is a Buddhist Temple complex and is one of the largest religious monuments in the world. It was originally constructed as a Hindu temple dedicated to the god Vishnu for the Khmer Empire. It was gradually transformed into a Buddhist temple towards the end of the 12<sup>th</sup> century. It combines two basic plans of the temple mountain and gallery temple. It is surrounded by a moat. In 1992 it was designated a world Heritage Site.



Angkor Wat  
Siem Reap, Cambodia

## Il Duomo

### Santa Maria Del Fiore Florence Cathedral

The Florence Cathedral, formerly the Cathedral di Santa Maria del Fiore, began construction in 1296 in the Gothic style based upon a design by Arnolfo di Cambio. It was structurally completed in 1436 with the dome that gave it identity. The architect Filippo Brunelleschi gained fame for winning the competition to design the dome. In the 19<sup>th</sup> century the building was faced with colored marble by Emilio De Fabris.

The Piazza Del Duomo includes three structures including the cathedral, the baptistery with its famous bronze doors by Lorenzo Ghiberti and the Campanile (bell tower) by Giotto. In 1982 it was designated a World Heritage Site.



Il Duomo  
Florence, Italy



# Center for Leadership Inspire Architecture Group Kids' Home Architecture Camp

## St. Peter's Basilica

The Papal Basilica of Saint Peter in the Vatican was completed by many great architects of the Renaissance who included: Donato Bramante, Michelangelo Bounorotti, Carlo Maderno and Gian Lorenzo Bernini, among others. Designed in the Renaissance Baroque style, it is considered the largest church in the world.

The Basilica is built over the tomb of St. Peter, the first Bishop of Rome and one of Jesus's apostles. Construction began in April of 1506 and was completed in November of 1626. In 1984, St. Peter's was designated a World Heritage Site.



St. Peter's Basilica  
Vatican City

## La Sagrada Familia



La Sagrada Familia  
Barcelona, Spain

The Basilica de la Sagrada Familia is a large Catholic Church in Barcelona, Spain. Work began on the project in 1882 under architect Francisco de Paula del Villar. In 1883 del Villar resigned, the commission was taken over by Antoni Gaudi, the Catalan architect who would become world renowned for this building. Unfortunately, Gaudi was struck by a street car in 1926 before the Basilica was complete. It stood unfinished for many years when Barcelona's leaders realized it needed to be finished or demolished. It is now being completed and is intended to be finished by the 100<sup>th</sup> anniversary of Gaudi's passing in 2026. In 2005, it was recognized as a World Heritage Site.

# Center for Leadership Inspire Architecture Group Kids' Home Architecture Camp

## Neuschwanstein Castle

Built as a palace for Ludwig II of Bavaria in the 19<sup>th</sup> Century, Neuschwanstein Castle was built to honor Richard Wagner, a famous composer of many world renowned operas. The castle became the home of the King until his death 1886 when it was opened to the public.

Construction began 1869 in Bavaria above the village of Hohenschwangau. It was in the Romanesque Revival style by architect Eduard Riedel, Christian Jank and others.



Neuschwanstein  
Bavaria, Germany

## Notre Dame du Haut Ronchamps

Built in 1955, the Roman Catholic chapel in Ronchamp, France was one of the early examples of the modern style of the Franco-Swiss architect, Le Corbusier. It was commissioned by the Association de l'Oeuvre Notre-Dame du Haut. In the design of the chapel, the architect drew inspiration from a crab shell. In 1967, Notre Dame du Haut was designated a World Heritage Site.

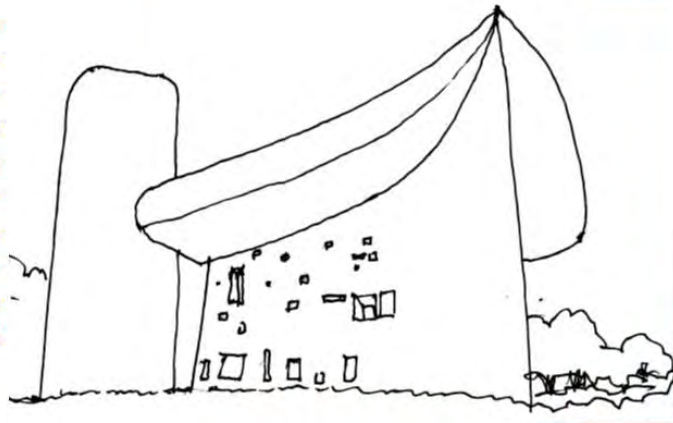

Notre Dame du Haut  
Ronchamps, France



# Center for Leadership Inspire Architecture Group Kids' Home Architecture Camp

## Barcelona Pavilion

The German pavilion for the 1929 International Exposition held in Barcelona, Spain was designed by architect Ludwig Mies van der Rohe and Lilly Reich. It is an important building in establishing the path for the modern movement in architecture. It featured a minimalist approach to the design of space. Along with the building, the architect designed furniture including the world famous Barcelona chair which is still regarded as an exemplary piece of modern furniture. The building featured a simple plan with large expanses of glass and walls of marble, onyx and travertine.



Barcelona Pavilion  
Barcelona, Spain

## Guggenheim Museum

New York City

Frank Lloyd Wright was the architect for the Solomon R. Guggenheim Museum in New York. Built in 1959 the landmark work features a cylindrical gallery space giving it a unique form. In 1992, the adjacent tower building designed by architects Gwathmey Siegel was constructed which acts as beautiful backdrop to the powerful statement of the Wright designed foreground main building. The original building includes an open atrium with a circular path as a connected gallery. In 2019, the Guggenheim was designated as a World Heritage Site.

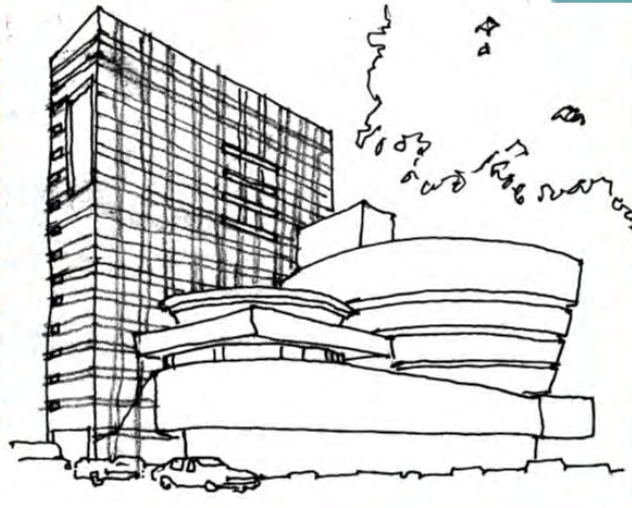

The Guggenheim Museum  
New York City, NY



# Center for Leadership Inspire Architecture Group Kids' Home Architecture Camp

## Sydney Opera House

The Sydney Opera House is a multi-performance space located in the harbor of Sydney, New South Wales, Australia. It is one of the most well recognized and unique buildings of the 20<sup>th</sup> century. Designed by the Danish architect Jørn Utzon, it was opened in 1973. Utzon obtained the commission through an international design competition. During the construction, conflicts between the government of New South Wales and the architect arose due to cost and scheduling overruns. As a result, the architect did not see the completed work. In 2007, the Opera House became a World Heritage Site.

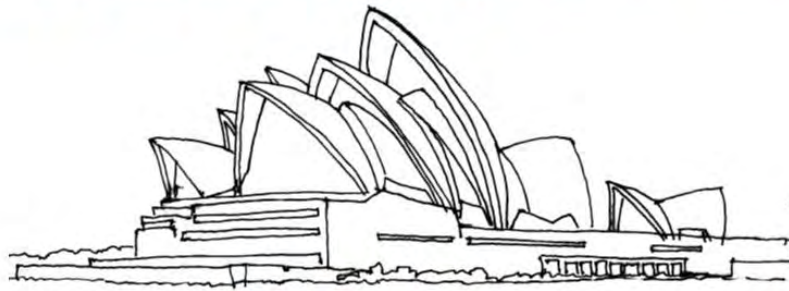

Sydney Opera House  
Sydney, Australia

## 10 Significant Buildings to Know

Through the study of these significant buildings, children will come to recognize the legacy they have been provided. By knowing these great works, they will gain a better understanding of the built environment and have examples of how to make it more beautiful.

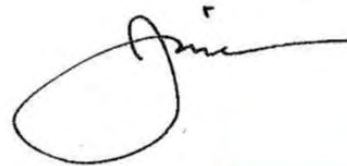

Center for Leadership  
Inspire Architecture Group  
Kids' Home Architecture Camp

## Drawing Credits/References

All drawings were created by the author.

Written resources include: Wikipedia articles that have been interpreted by the author.

# Center for Leadership

## Inspire Architecture Group

### Kids' Home Architecture Camp

## Section 7: Sustainability

### Lesson

To rally countries to work and pursue sustainable development together, the UN established the Brundtland Commission in 1983. Gro Harlem Brundtland, who was the former Prime Minister of Norway, was chosen due to her strong background in the sciences and public health. The Brundtland Commission officially dissolved in December 1987 after releasing "Our Common Future", also known as the Brundtland Report, in October 1987. The document popularized (and defined) the term "Sustainable Development". "Sustainable development" is development that meets the needs of the present without compromising the ability of future generations to meet their own needs." Over 35 years, we continue to struggle with how we can live up to this objective.

Today, more than ever, we are challenged to build a future for the next generation. In that regard, understanding the philosophy, technology and strategies for producing a sustainable future is critical to achieving this objective. In this section, we will make consider some of these areas and consider how students can make a contribution within their own homes and communities in pursuit of a sustainable future.

We live on "spaceship earth" and it has a finite number of resources. When they are used up, they are gone. Therefore, sustainability is fundamentally about the careful use of resources to maximize benefit and longevity. These resources include: water, food, air, energy, material, people, environment, nature, animals and land. Each one is dependent on the other. What we do to one element can have a serious impact on all the others. Recognizing this interdependence is critical to creating strategies to preserve each one.

Several organizations have introduced systems for certifying and recognizing buildings for their commitment to environmental stewardship. Among these are Green Globes, the National Association of Home Builders Association Green Guidelines and the United States Green Building Council (USGBC), a quasi-governmental organization, LEED Certification. In 1998, the USGBC developed and introduced the LEED System (Leadership in Energy and Environmental Design). It was produced as a means to have a third party validate a building's achievement in environmental and energy efficiency.

The LEED rating system established six areas where buildings should address environmental and energy standards to be recognized for their achievement. These areas include: sites, water efficiency, energy and atmosphere, materials and resources, indoor environmental quality and innovation in design. Applicants earn credits toward certification towards four levels of achievement including: certified, silver, gold and platinum. It goes on to suggest that there are different targets for building types and regions relative to the requirements and standards they should attempt to realize. The process would be produced by individuals, who have been accredited as "LEED Green Associates and LEED Accredited Professionals". The procedure focuses on aspiration and achievement placing a great deal of emphasis on energy modeling. It has become highly recognized and utilized in pursuing a more sustainable future.

Even with the noted measures being deployed, there are still many dire time lines that have been put forward suggesting a failure to take measures to change the way we act will result in a global catastrophe. It is up to us to be part of the answer and identify ways in which we can contribute to solutions and not just expand the problem kicking it down the road for others to deal with the consequences.



# Center for Leadership Inspire Architecture Group

## Kids' Home Architecture Camp

Let's look at areas where we can act locally and in our homes to make a difference. The challenge is to answer the question: "How might we"

45. consume less energy?
46. make better use of water resources?
47. protect the environment?
48. reduce pollutants to the air and water?
49. reduce waste?
50. preserve animals?
51. produce sustainably responsible products and businesses?
52. develop safe, healthy and plentiful food for all?
53. increase forests?
54. create healthy places to live, work, recreate and educate?

Based upon these questions, we can explore strategies and actions we can take to make a difference. Those actions may include such things as: considering light sources and energy, using water saving devices, devising recycling programs, consider what we throw "away" and where we do it. In addition, we might look at devising alternate energy systems for our home or community, look at how much we use our cars and consider walking, biking or public transit, plant trees, open the window for fresh air, look at the contents of the products we buy to evaluate them for environmental responsibility.

### Activities

Older Students- "Sustainability Scavenger Hunt" using the **Sustainability Home Survey** form on the following page, go around your house and yard look at the things that are there in each category and determine what you might suggest to be more sustainable.

Younger students- Talk with them about sustainability and ask what they think a sustainable future might look like. Create a poster to encourage doing something in a more sustainable way.

Material needed: paper, crayons, pencils, scissors and tape

# Center for Leadership Inspire Architecture Group

## Kids' Home Architecture Camp

### Sustainability Home Survey

CATEGORY	RECOMMENDATION	LOCATION
SITE		
BUILDING ENVELOPE		
MATERIALS & RECYCLING		
LIGHTING		
ELECTRICAL		
ENERGY EFFICIENCY		
WATER QUALITY		
WATER QUANTITY		
AIR QUALITY		
MECHANICAL SYSTEMS		
ALTERNATIVE ENERGY		
INNOVATION		
DAYLIGHTING		

# Center for Leadership Inspire Architecture Group Kids' Home Architecture Camp

## Conclusion:

My sincere hope is that the lessons, activities and projects contained within this document are useful for parents and entertaining as well as educational for children. While at home, we can learn to better appreciate the environment, that for the moment, we are unable to directly interact with and engage. I also hope both students and parents will gain an appreciation for architecture and learn to recognize that design matters and can be a powerful tool when carefully considered.

I want to leave you with three ideas that you can explore during this “time out period”:

1. Read as much as you can. This activity will fill your days and the ideas that you gain will fill your mind.
2. Always have a pen or pencil and a notebook or sketchbook. This is where your ideas can emerge, incubate and grow.
3. Look at the world through inquisitive eyes, question why things are the way they are and what you might do differently to improve them and make a difference.

Best wishes for good health and enjoy what the “Kids Home Architecture Camp” can provide for you and your children.

Sincerely,



Judson A. Kline, FAIA, NCARB, LEED AP  
President, CIVITAD Services, LLC  
Adj. Professor, Kent State University  
College of Architecture and Environmental Design  
Adj. Professor, North Coast College  
Councilman, Orange Village, Ohio  
AIA Ohio, Ex Officio